

## PORTABLE HYDRAULIC POWER UNIT

w/Autostart

Model HSP-KDI2504TCR FT4

Shown with  
Optional Wheel Kit

## HYDRAULIC SPECIFICATIONS

**Hose Ports:** 1" N.P.T.**Hydraulic Pump:** Pressure Compensated Piston Type.**Hydraulic Output:** Variable, Max 28 GPM (121 LPM).**Maximum Operating Pressure:**

2900 PSI (200 Bar);

3000 PSI [206 Bar] Bypass.

**Hydraulic Oil:** Biodegradable Hydraulic Oil.**Hydraulic Oil Reservoir Capacity:** 45 U.S. Gallons (189 Liters).**Standard Equipment:** Lifting Bail, Combination Skid Base w/Fuel Tank, Pressure Control Valve, System Relief Valve, Spin-on Return Filter w/Indicator, Fluid Level/Temperature Gauge, Tank Top Filler/ Strainer, Variable Speed Control, Liquid Filled Pressure Gauge and Single Ball Type Float Switch\*\*.**Optional Equipment:** Battery. High Speed (55 MPH/89 KM/H) Single Axle Pneumatic-Tired Wheel Kit w/two DOT-Approved Lights and Electric Brakes. Tandem Axle Over-the-Road Trailer (Meets DOT Requirements) Available w/Either Electric or Hydraulic Surge Brakes, Running Lights, Jack Stands and Safety Cables/Chains. EPS w/Submersible Transducer Liquid Level Sensor (50 Ft. [15 M] Cable Standard, Alternate Lengths Available). 1.00" (25,4 mm) Hydraulic Hoses with Quick Disconnect Fittings Available in 50 Foot [15,2 Meter] Increments; Maximum Recommended Length 150 Feet [45,7 Meters] Specify Length at Time of Order. Two-Float Switch Kit.**\*\*50 Ft. (15 m) Standard Length; Dual Switches and Alternate Cable Lengths Available From the Factory.**

## ENGINE SPECIFICATIONS

**Model:** KOHLER KDI2504TCR.**EPA Tier:** Tier 4.**Type:** Four Cylinder, Four Cycle, Turbocharged, Liquid Cooled Diesel Engine.**Displacement:** 151 Cu. In. (2,4 Liters).**Governor:** Electronic.**Lubrication:** Forced Circulation.**Air Cleaner:** Dry Type.**Fuel Tank:** 88 U.S. Gallons (333 Liters).**Full Load Operating Time:** 31.0 Hrs.**Starter:** 12V Electric.**Standard Features:** Muffler w/ Weather Cap, DOC Exhaust After-Treatment System.**Engine Control Features:** Padlockable Box with Throttle Control, Tachometer, Coolant Temperature, Oil Pressure, Voltage and Overstart Indicators/Shutdowns. Manual/Stop/Auto Key-switch. Audible Startup Warning Delay. Fuel Level Display/Alarm/Shutdown Electronic Fuel Level Sensor.**KOHLER PUBLISHED PERFORMANCE:**  
Maximum Gross Intermittent Industrial B.H.P.  
74 (55 kW) @ 2600 RPM

GORMAN-RUPP PUMPS

www.grpumps.com

Specifications Subject to Change Without Notice

Printed in U.S.A.

# Specification Data

APPROXIMATE DIMENSIONS and WEIGHTS

	SKID BASE	WHEEL KIT
NET WEIGHT (Dry):	2600 LBS. (1179,3 KG.)	3075 LBS. (1394,8 KG.)
SHIPPING WEIGHT:	2750 LBS. (1247,4 KG.)	3075 LBS. (1394,8 KG.)
EXPORT CRATE SIZE:	345 CU. FT. [9,8 CU. M.]	750 CU. FT. [21.2 CU. M.]

SECTION 140, PAGE 1750

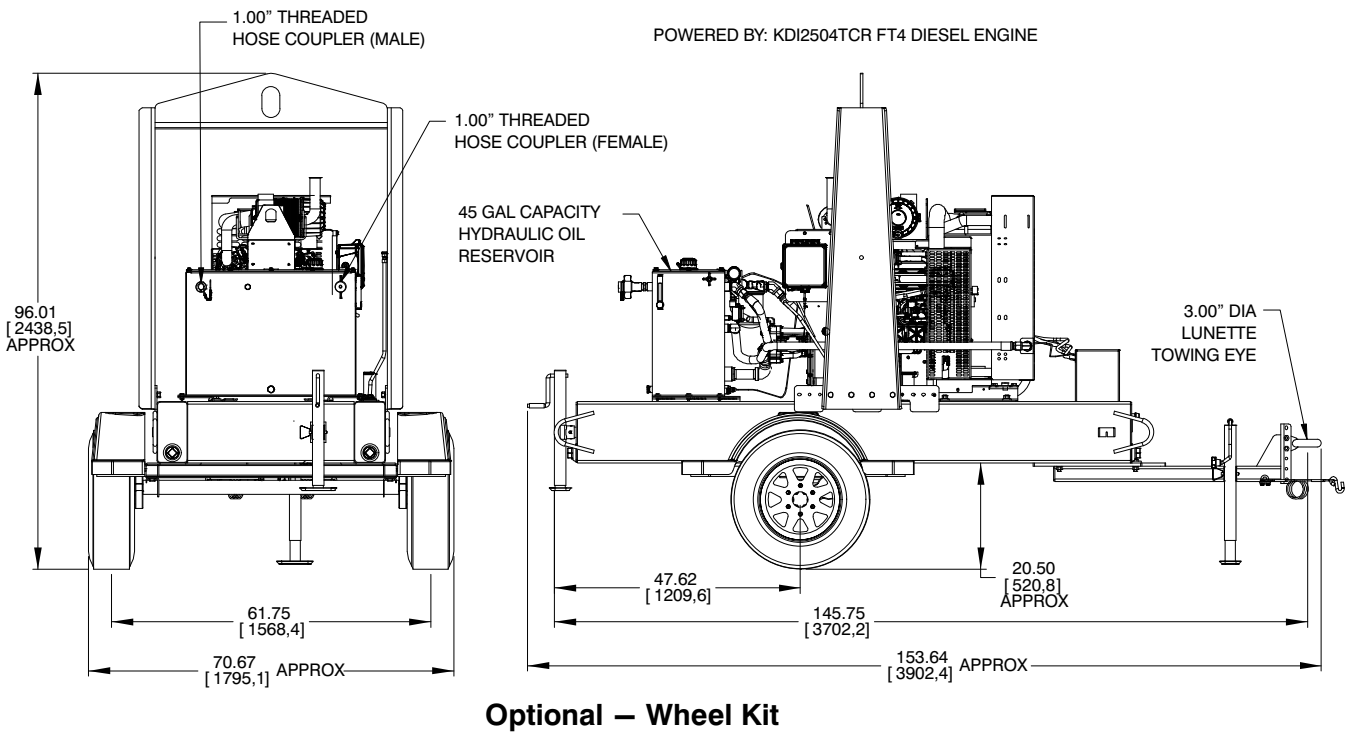
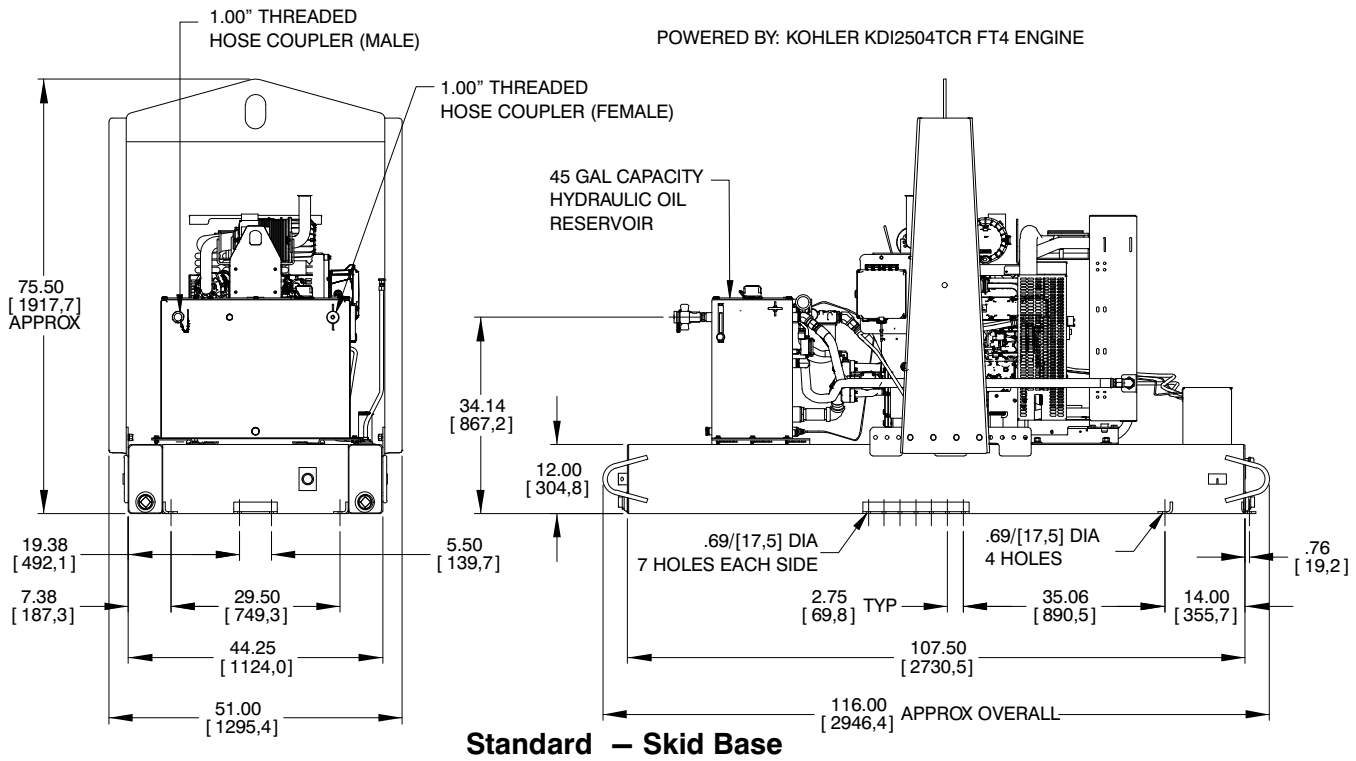

## GORMAN-RUPP PUMPS

www.grpumps.com

Specifications Subject to Change Without Notice

Printed in U.S.A.