

---

# **S**SERIES

---

## **INSTALLATION, OPERATION, PARTS LIST, AND MAINTENANCE MANUAL**



**THE GORMAN-RUPP COMPANY • MANSFIELD, OHIO**

GORMAN-RUPP OF CANADA LIMITED • ST. THOMAS, ONTARIO, CANADA

Printed in U.S.A.

© Copyright by the Gorman-Rupp Company 1985



# TABLE OF CONTENTS

INTRODUCTION . . . . .	I-1
WARNINGS - SECTION A . . . . .	A-1
INSTALLATION - SECTION B . . . . .	B-1
PREINSTALLATION INSPECTION . . . . .	B-1
Lubrication . . . . .	B-2
PUMP INSTALLATION . . . . .	B-2
Pump Specifications . . . . .	B-2
Pump Dimensions . . . . .	B-2
Lifting . . . . .	B-3
Positioning The Pump . . . . .	B-4
Piping . . . . .	B-5
CONTROL BOX INSTALLATION . . . . .	B-6
Enclosure . . . . .	B-6
Dual Voltage Motor Wiring Instructions . . . . .	B-6
Grounding Methods . . . . .	B-9
Field Wiring Connections (Incoming Power) . . . . .	B-10
Pump Power Cable Connections . . . . .	B-11
LIQUID LEVEL DEVICES . . . . .	B-12
OPERATION - SECTION C . . . . .	C-1
CONTROL BOX FUNCTION . . . . .	C-1
Component Function . . . . .	C-1
PUMP OPERATION . . . . .	C-2
Liquid Temperature And Overheating . . . . .	C-2
Checking Pump Rotation . . . . .	C-3
STARTING . . . . .	C-4
Standard Pump (No Liquid Level Devices) . . . . .	C-5
With Automatic Liquid Level Devices . . . . .	C-5
STOPPING . . . . .	C-5
Operation Checks . . . . .	C-6
Cold Weather Preservation . . . . .	C-6
TROUBLESHOOTING - SECTION D . . . . .	D-1
TROUBLESHOOTING CHART . . . . .	D-1
ELECTRICAL TESTING . . . . .	D-4
Test Equipment . . . . .	D-4
Voltage Imbalance . . . . .	D-4
Motor And Motor Power Cable Continuity . . . . .	D-5
Insulation Resistance . . . . .	D-6
MAINTENANCE AND REPAIR - SECTION E . . . . .	E-1
PERFORMANCE CURVE . . . . .	E-1
PUMP MODEL - PARTS LIST . . . . .	E-3
PUMP AND MOTOR DISASSEMBLY AND REASSEMBLY . . . . .	E-4
PUMP END DISASSEMBLY . . . . .	E-5
Strainer Disassembly . . . . .	E-5
Draining Oil From Seal And Motor . . . . .	E-5
Positioning Pump For Disassembly . . . . .	E-5
Impeller Disassembly . . . . .	E-6
Lower Seal Disassembly . . . . .	E-6
Upper Seal Disassembly . . . . .	E-7
PUMP END REASSEMBLY . . . . .	E-7
Cleaning Old Parts . . . . .	E-7
Upper Seal Reassembly . . . . .	E-9
Lower Seal Reassembly . . . . .	E-10
Impeller Reassembly . . . . .	E-11
Diffuser, Wear Plate And Screen Reassembly . . . . .	E-12
MOTOR DISASSEMBLY . . . . .	E-12
Terminal Housing And Power Cable Disassembly . . . . .	E-13

Pump Casing And Motor Housing Disassembly . . . . .	E-14
Rotor Disassembly . . . . .	E-15
Stator Disassembly . . . . .	E-15
Hoisting Bail . . . . .	E-16
MOTOR REASSEMBLY . . . . .	E-16
Stator Reassembly . . . . .	E-17
Rotor Reassembly . . . . .	E-17
Motor Housing And Pump Casing Reassembly . . . . .	E-19
Terminal Housing And Power Cable Reassembly . . . . .	E-19
Power Cable Potting . . . . .	E-20
LUBRICATION . . . . .	E-23
Seal Cavity . . . . .	E-24
Motor Housing Cavity . . . . .	E-24
FINAL ASSEMBLY . . . . .	E-24

INTRODUCTION

This Installation, Operation, and Maintenance Manual is designed to help you achieve the best performance and longest life from your Gorman-Rupp pump.

This pump is designed to operate fully or partially submerged. It is capable of handling most nonvolatile and nonflammable liquids which are mildly corrosive and abrasive. The basic material of construction is CD4MCu stainless steel, with 316 stainless steel rotor shaft, motor housing and hardware. The pump is designed to handle industrial chemical and low pH resistance materials. The integral dual voltage electric motor must be operated through the control box furnished with the pump. Neither the pump motor nor control box are explosion proof and should not be operated in a hazardous atmosphere.

If there are any questions regarding the pump or motor which are not covered in this manual or in other literature accompanying this unit, please contact your Gorman-Rupp distributor or the Gorman-Rupp Company:

The Gorman-Rupp Company  
P.O. Box 1217  
Mansfield, Ohio 44901-1217

or

Gorman-Rupp of Canada Limited  
70 Burwell Road  
St. Thomas, Ontario N5P 3R7

The following are used to alert maintenance personnel to procedures which require special attention, to those which could damage equipment, and to those which could be dangerous to personnel:

NOTE

Instructions to aid in installation, operation, and maintenance or which clarify a procedure.

CAUTION

Instructions which must be followed to avoid causing damage to the product or other equipment incidental to the installation. These instructions describe the requirements and the possible damage which could result from failure to follow the procedures.

WARNING

////////////////////////////////////  
//  
// These instructions must be followed to avoid causing in- //  
// jury or death to personnel, and describe the procedure //  
// required and the injury which could result from failure //  
// to follow the procedure. //  
// //  
////////////////////////////////////



WARNINGS

WARNINGS - SECTION A

THESE WARNINGS APPLY TO THE "S-SERIES" SUBMERSIBLE MOTOR OPERATED PUMPS.

WARNING

```

////////////////////////////////////
//
// Before attempting to open or service the pump:
//
// 1. Familiarize yourself with this manual.
// 2. Lock out the motor to the control panel to ensure
//    that the pump will remain inoperative.
// 3. Allow the pump to cool if overheated.
// 4. Close the discharge valve (if used).
//
////////////////////////////////////

```

WARNING

```

////////////////////////////////////
//
// Do not attempt to pump volatile or flammable liquids for
// which this pump has not been designed.
//
////////////////////////////////////

```

WARNING

```

////////////////////////////////////
//
// Before connecting any cable to the control box, be sure
// to ground the control box. See Figure 5 on page B-9 for
// suggested grounding methods.
//
////////////////////////////////////

```

WARNING

```

////////////////////////////////////
//
// After the pump has been installed, make certain that the
// pump and all piping or hose connections are secure be-
// fore operation.
//
////////////////////////////////////

```

WARNING

```

////////////////////////////////////
//
// The pump motor is designed to be operated through the
// control box furnished with the pump. The control box
// provides overload protection and power control. Do not
// connect the pump motor directly to the incoming power
// lines.
//
////////////////////////////////////

```

WARNINGS

WARNING

```

////////////////////////////////////
//
// All electrical connections must be in accordance with //
// the National Electric Code and all local codes. If //
// there is a conflict between the instructions provided //
// and N.E.C. specifications, N.E.C. specifications shall //
// take precedence. All electrical equipment supplied with //
// this pump was in conformance with N.E.C. requirements in //
// effect on the date of manufacture. Failure to follow //
// applicable specifications, or substitution of electrical //
// parts not supplied or approved by the manufacturer, can //
// result in severe injury or death. //
//
////////////////////////////////////

```

WARNING

```

////////////////////////////////////
//
// The electrical power used to operate this pump is high //
// enough to cause injury or death. Make certain that the //
// control box is grounded, and that the power supply is //
// compatible with the motor phase and voltage, before con- //
// necting the power source. If the overload unit is //
// tripped during pump operation, correct the problem be- //
// fore restarting the pump. //
//
////////////////////////////////////

```

WARNING

```

////////////////////////////////////
//
// Obtain the services of a qualified electrician to con- //
// nect the electrical circuits, and to service the control //
// box. //
//
////////////////////////////////////

```

WARNING

```

////////////////////////////////////
//
// Do not attempt to lift the pump by the motor power cable //
// or the piping. Attach proper lifting equipment to the //
// hoisting bail fitted to the pump. //
//
////////////////////////////////////

```



---

---

## INSTALLATION - SECTION B

This section is intended only to summarize recommended installation practices for the pump and control box. If there are any questions concerning your specific installation, contact your Gorman-Rupp distributor or the Gorman-Rupp Company.

Automatic liquid level devices are not furnished with the standard pump, but are available from Gorman-Rupp as options (see **Liquid Level Devices**, Section B); for information on installing and operating these devices, see the technical data accompanying that option.

### PREINSTALLATION INSPECTION

The pump assembly and control box were inspected and tested before shipment from the factory. Before installation, check for damage which may have occurred during shipment. Check as follows:

- a. Check the pump assembly for cracks, dents, damaged threads, and other obvious damage.
- b. Check for and tighten loose attaching hardware. Since gaskets tend to shrink after drying, check for loose hardware at mating surfaces.
- c. The standard pump is connected to the control box with 50 ft. of power cable. Inspect the cable for cuts or damage.
- d. Check the control box for cracks, dents, and other obvious damage.
- e. Check that all control box components are securely attached to their mounting surfaces, and that the electrical connections are tight and free of corrosion.
- f. Compare the amperes, phase, voltage, and hertz indicated on the motor name plate to the ratings indicated for the control box.
- g. Carefully read all tags, decals, and markings on the pump assembly and the control box, and perform all duties indicated.
- h. Check the pump and motor for any oil leaks. An oil leak may indicate a cut O-ring or other damage.
- i. If the pump and control box have been stored for more than 12 months, some of the components or lubricants may have exceeded their maximum shelf life. These **must be inspected or replaced** to insure maximum pump service.

If the maximum shelf life has been exceeded, or if anything appears to be abnormal, contact your Gorman-Rupp distributor or the factory to determine the repair or updating policy. **Do not** put the pump into service until appropriate action has been taken.

---



---

**INSTALLATION**

---



---

**Lubrication**

There are two lubrication cavities in this pump, both contain premium quality submersible pump oil. The motor housing cavity provides lubrication to the motor assembly and rotor shaft bearings. The intermediate cavity provides lubrication to the seal assembly.

There are two shaft seals in this pump. The lower seal prevents liquid from entering the intermediate cavity at the impeller end. The upper seal prevents oil leakage from the motor housing cavity and acts as back-up protection in the event of lower seal failure.

Both cavities are fully lubricated when the pump is shipped from the factory. Check lubrication levels before installing the pump (see **LUBRICATION in MAINTENANCE AND REPAIR**). An additional quart of oil has been provided with the pump to "top off" the oil cavities. If either oil level is abnormally low, determine the cause before putting the pump into service.

**PUMP INSTALLATION****Pump Specifications**

See Table 1 for the typical pump specifications and motor data.

**Table 1. Pump Specifications**

Model Number	Voltage/Phase	Pump Horsepower	Motor Speed (RPM)	Full Load Amperes	No Load Amperes	Locked Rotor Amperes	Discharge Size (NPT)
S4D65	230/3	10	3450	34	7	148	4
S4D65	460/3	10	3450	17	3.5	74	4

**Pump Dimensions**

The standard pump is provided with a suction strainer to prevent large solids from clogging the impeller. On high discharge head applications, the strainer can be replaced with an optional staging adaptor to allow one pump to feed another.

See Figure 1 on page B-3 for the approximate physical dimensions of the pump.

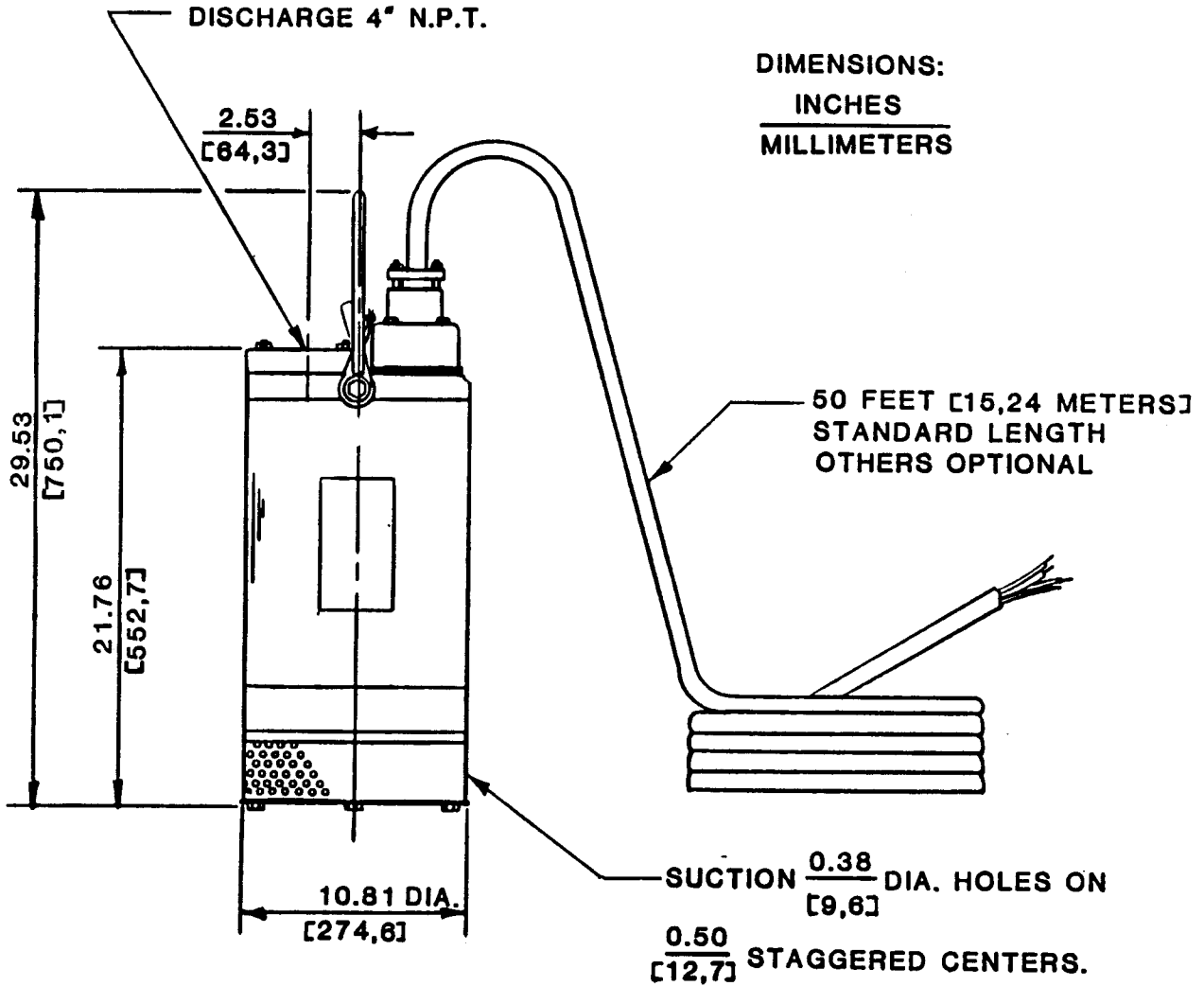

Figure 1. Pump Model S4D65-E10 460V 3P

Lifting

Use lifting equipment with a capacity of at least 1,000 pounds. This pump weighs approximately 190 pounds, not including the weight of accessories and control box. Customer installed equipment such as rigid piping **must** be removed before attempting to lift.

WARNING

```

////////////////////////////////////
//
// Do not attempt to lift the pump by the motor power cable //
// or the piping. Attach proper lifting equipment to the //
// hoisting bail fitted to the pump. If chains or cable //
// are wrapped around the pump to lift it, make certain //
// that they are positioned so as not to damage pump, and //
// so that the load will be balanced. //
// //
////////////////////////////////////

```

Positioning The Pump

This pump is designed to operate fully or partially submerged. It may also be operated in air for extended periods. The rotating parts are oil lubricated, and the motor is cooled by a constant flow of liquid or air discharged through internal passage(s).

The pump will operate if positioned on its side, but this is not recommended because the motor torque could cause the pump to roll during operation.

The pump should be independently secured and supported by the hoisting bail. If the application involves a lot of debris, protect the pump from excessive wear and clogging by suspending it in a perforated barrel or culvert pipe. If the bottom is heavily sludge-covered, rest the pump on support blocks or suspend it from a raft or similar device near the surface of the liquid. See Figure 2 on page B-5 for typical pump installations.

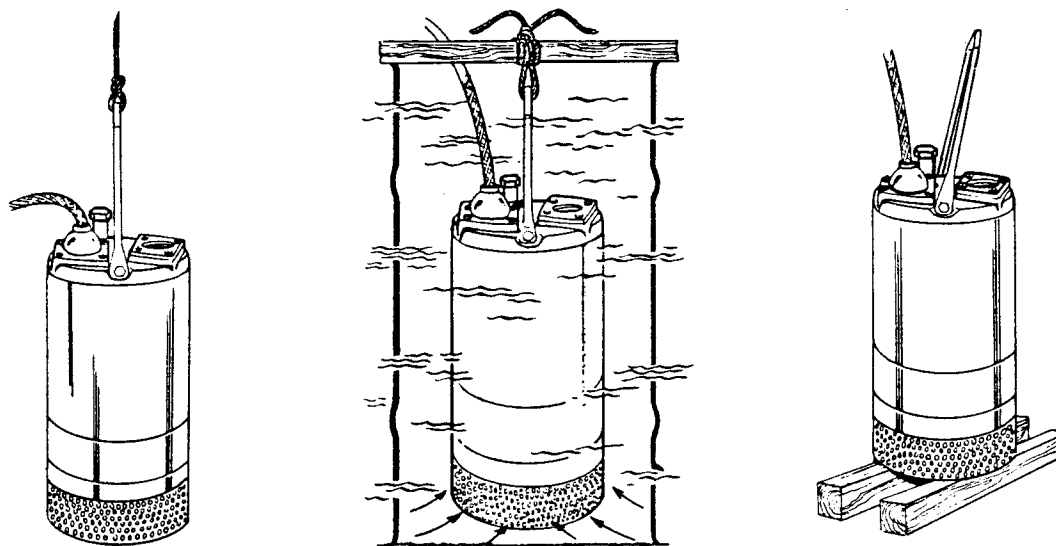

BY BAIL

IN BARREL

ON TIMBERS

Figure 2. Typical Pump Installations.

All liquid entering the pump must pass through a strainer screen. Any spherical solids which pass through the screen will pass through the pump.

#### NOTE

Before actual operation, check the direction of impeller rotation to ensure that the pump is properly wired to the control box. See **Checking Pump Rotation** in **OPERATION** section.

#### Piping

No suction piping is required in a standard submerged application.

If an optional suction staging adaptor is installed, the discharge from one pump may be piped to the suction of another. To determine the size of the discharge connection, see Table 1, PUMP SPECIFICATIONS. Either hose or rigid pipe may be used. To facilitate mobility and maintenance, it is recommended that the discharge line be fitted with a quick disconnect fitting near the pump. The discharge line must be independently supported to avoid strain and vibration on the pump.

INSTALLATION

For maximum pumping capacity, keep the discharge as short and straight as possible. Minimize the use of elbows and fittings which increase friction losses through the discharge piping system.

It is recommended that a check valve or throttling valve be installed in the discharge line to control siphoning or back flow when the pump is shut off.

CONTROL BOX INSTALLATION

This pump is driven by an integral 460 VAC, 60 hertz, 3 phase, 10 HP motor. It is designed to operate through the control box furnished with the pump.

WARNING

Warning text enclosed in a double-line border with slashes at the corners. The text reads: 'The pump motor is designed to be operated through the control box furnished with the pump. The control box provides overload protection and power control. Do not connect the pump motor directly to the incoming power lines.'

Enclosure

The control box is a rainproof enclosure with a padlockable front cover. The enclosure is not designed to be watertight, and should not be submerged. See Figure 4 on page B-8 for enclosure dimensions and callouts.

Secure the control box vertically on a level surface, which is above flood level. It should be easily accessible to the operator, and located close enough to the pump to avoid excessive voltage drop due to cable length. (See Pump Power Cable Connections). After the box is installed, make certain the front cover latches properly.

CAUTION

Failure to mount the control box vertically on a level surface may affect operation of the pump controls.

Dual Voltage Motor Wiring Instructions

This pump is powered by a dual-voltage motor which permits utilization of high or low voltage. The motor was originally wired and shipped for the voltage indicated as "Factory Wired" on the pump's name plate. The name plate also indicates the dual voltages pertaining to this motor. If the alternate voltage must be utilized, certain wiring and control box modifications are required.

---



---

 INSTALLATION
 

---



---

The control box assembly provided with this pump has been designed to accommodate **only** the voltage indicated on the front of the box. This voltage coincides with the "Factory Wired" voltage of the motor. If the alternate voltage is utilized, the control box must be replaced with another box designed for the appropriate voltage. Consult the Parts List under Options (Section E, Page 3) to determine the part number of the alternate control box.

The motor wiring **must** also be changed before utilizing the alternate voltage. For detailed instructions on disassembly and reassembly of the terminal housing, see **Terminal Housing and Power Cable Disassembly and Terminal Housing and Power Cable Reassembly** in this manual (Section E). Change the motor leads as indicated on the wiring diagram plate affixed to the side of the terminal housing, see Figure 3. Be sure to tag the revised voltage on the pump.

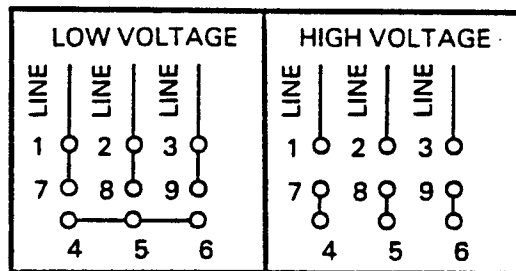

Figure 3. Motor Wiring Diagram

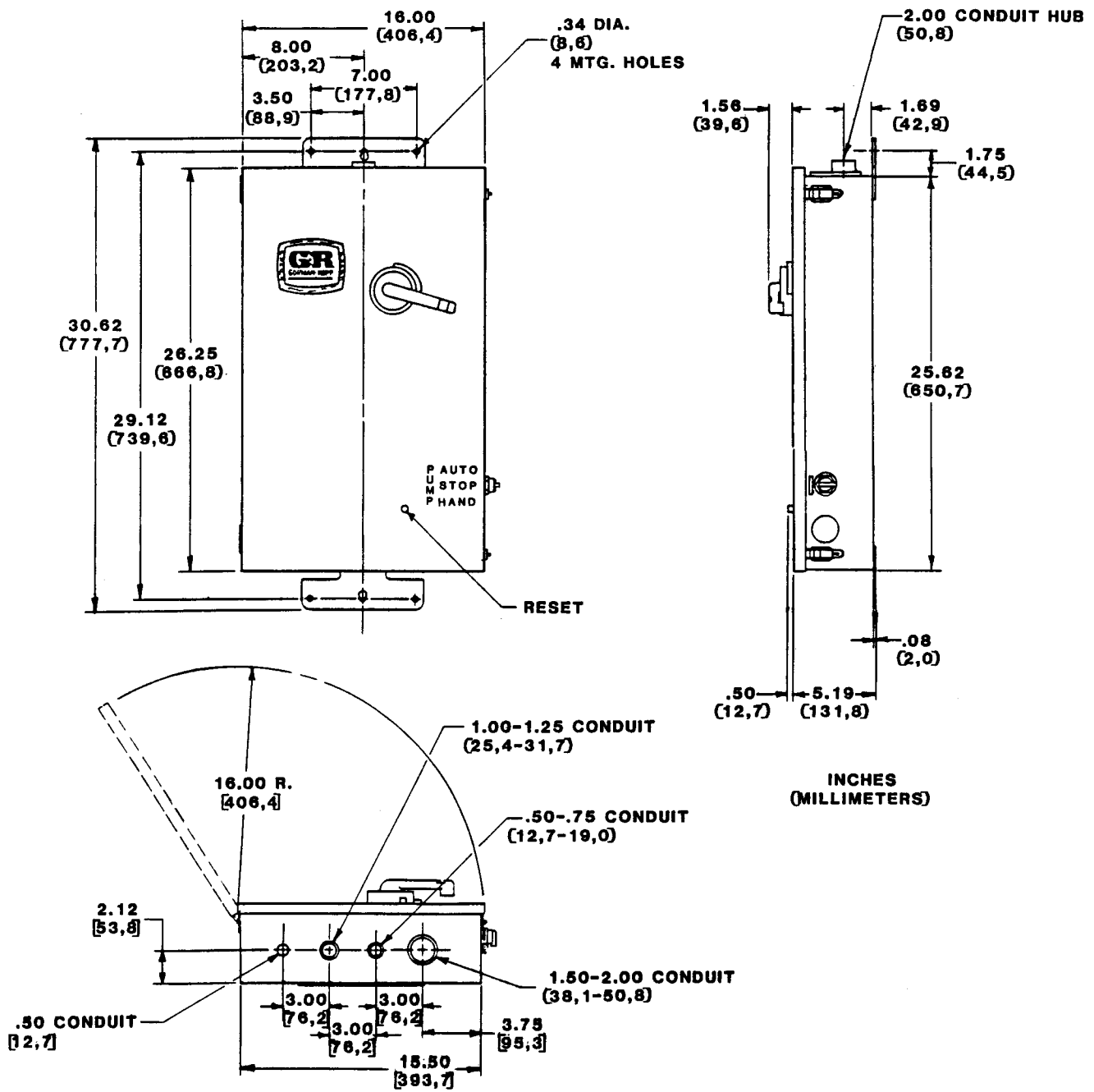

Figure 4. 27514-325 Control Box Assembly



## Grounding Methods

Electrically ground the installation before connecting the field wiring to the control box. Install a grounding terminal to the enclosure and connect it to a properly imbedded electrode.

The material used for the electrode **must** be an excellent conductor of electricity, such as copper. If iron or steel is used, it must be galvanized or otherwise metal plated to resist corrosion. **Do not** coat the electrode with any material of poor conductivity such as paint or plastic.

The electrode must conform to the recommendations of N. E. C. Article 250. Follow all installation requirements of the N.E.C., and all applicable local codes. See Figure 5 for some suggested grounding methods.

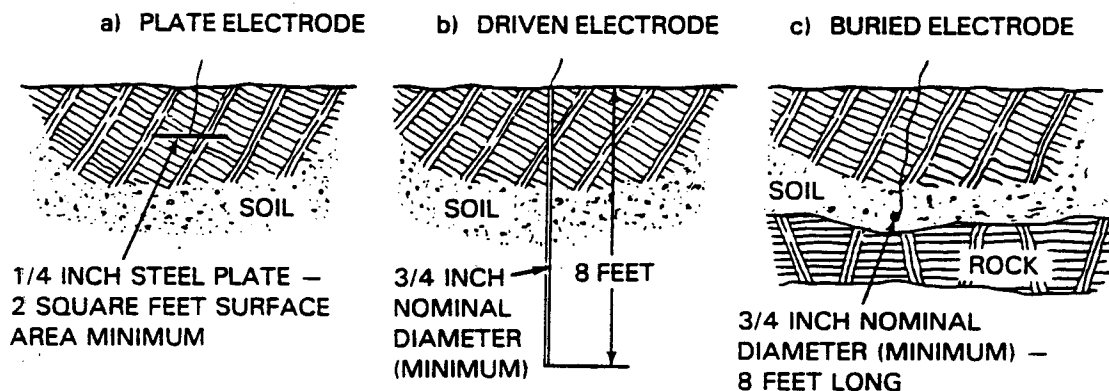

Figure 5. Suggested Grounding Methods

- Plate Electrode:** An iron or steel plate, 1/4 inch thick, completely imbedded in the ground. The plate must present a surface of a least 2 square feet.
- Driven Electrode:** A rod or pipe, 3/4 inch diameter minimum, 8 feet long, completely driven into the ground.
- Buried Electrode:** If rock or stone prevents imbedding the full 8 foot length of the ground rod, bury it in a horizontal trench.

Space the ground rod or plates at least 6 feet from any other electrode or ground rod, such as those used for signal circuits, radio grounds, lightning rods, etc.

The earth surrounding the ground rod or plate **must** contain enough moisture to make a good electrical connection. In dry or sandy areas, pour water around the rod or consult qualified personnel to devise a method of improving the connection.

WARNING

```

////////////////////////////////////
//
// The electrical power used to operate this pump is high //
// enough to cause injury or death. Make certain that the //
// control box is properly grounded after installation. //
//
////////////////////////////////////

```

Field Wiring Connections (Incoming Power)

WARNING

```

////////////////////////////////////
//
// The electrical power used to operate this pump is high //
// enough to cause injury or death. Obtain the services of //
// a qualified electrician to make all electrical con- //
// nections. Make certain that the pump and enclosure are //
// properly grounded, and that the incoming power matches //
// the requirements of the pump and control. //
//
////////////////////////////////////

```

The pump control is designed to regulate a 460 volt, 3 phase, 60 hertz power supply. The field wiring must be properly sized to insure an adequate voltage supply. The voltage available at the motor must be within the range indicated in Table 2.

To calculate the voltage available at the motor proceed as follows:

- a. Measure the incoming voltage across lines (1 & 2, 2 & 3, and 1 & 3.) while the pump is **operating at full capacity**. See Figure 7 on page B-14 or Figure 8 on page B-15..
- b. Next; subtract the motor cable voltage drop (see Table 3, Motor Cable Specifications).
- c. Do not continue to operate the pump if this voltage is not within the recommended limits. Obtain the services of a qualified electrician to determine the correct field wiring size and other details to insure an adequate voltage supply to the pump.

Table 2. Pump Motor Voltage Limits

Nominal Voltage	Phase	Minimum Voltage	Maximum Voltage
230	3	210	250
460	3	420	500

Use conduit or cable clamps to secure the incoming field wiring to the control box. Make certain all connections are tight and that cable entry points are rainproof. Support the cable weight, if required, to prevent excessive strain on cable clamps and cable.

Pump Power Cable Connections

WARNING

Warning text enclosed in slashes: The electrical power used to operate this pump is high enough to cause injury or death. Make certain that incoming power is OFF and LOCKED OUT before connecting power or accessory cables to the control box. Obtain the services of a qualified electrician to make all electrical connections.

The standard pump is provided with a 50-foot power cable sealed by heat-shrink tubing in the terminal housing assembly. (See Table 3 for cable specifications.) If a longer power cable is required, an optional cable assembly must be ordered from the factory. Splicing of the power cable is not recommended by the Gorman-Rupp Company due to safety and warranty considerations.

WARNING

Warning text enclosed in slashes: Never attempt to alter the length or repair any power cable with a splice. The pump motor and cable must be completely waterproof. Injury or death may result from alterations.

Table 3. Cable Requirements for Pump Electrical Connections, Model S4D65

Table with 7 columns: Voltage/Phase, A.W.G. Cable Size, Cable OD (inches), Conductor Dia. (inches), Amp Rating\* at 40°C (amperes), DC Resistance at 25°C (ohms/1000 ft), Voltage Drop at Max. Load per 100 ft. Rows include 230/3 and 460/3 configurations.

\*Applies only to GGC type cable. Refer to manufacturer's specifications for other cable.

Before connecting the pump power cable to the control box, make certain the incoming power is OFF and LOCKED OUT. Make certain the control box is PROPERLY GROUNDED and that the electrical data on the control matches the motor name plate data.

---

---

Connect the pump power cable to the control box as shown in Figure 7 on page B-14 or Figure 8 on page B-15.. Use conduit or cable clamps to secure the power and accessory cables to the control box. Make certain that all connections are tight and that cable entry points are rainproof.

#### NOTE

The power cable furnished with this pump includes three electrical conductors (white, red, and black), two grounding conductors (green) and one ground check conductor (yellow). The yellow ground check lead is used in conjunction with customer supplied ground monitoring equipment. If this equipment is not used, the yellow lead should be connected with the green leads and used as a ground conductor.

#### LIQUID LEVEL DEVICES

The standard pump is **not** furnished with a means to automatically regulate liquid level. However, the pump may be controlled to perform filling, or dewatering functions by using **either** of the following optional sensing devices: (see Figure 6 on page B-13).

- **Diaphragm Type:** two fixed position sensors (upper and lower) each contain a diaphragm which flexes with changes in liquid level, thus activating an enclosed miniature switch.
- **Bulb (Float) Type:** a bulb raises or lowers (floats) with the liquid level, thus activating an enclosed miniature switch.

For added safety, the sensing devices operate through low voltage (24 volt) circuitry which is specially designed to fit into the main pump control box.

The circuitry may be prewired as a factory option, or easily added in the field by qualified personnel. For installation and operation, see the detailed instructions included with the optional package.

#### CAUTION

Liquid level devices **MUST** be positioned far enough apart to allow 10 minutes between starts. If the pump motor cycles more than 6 starts per hour, it will overheat resulting in damage to the motor windings or control box components.

TYPICAL INSTALLATION

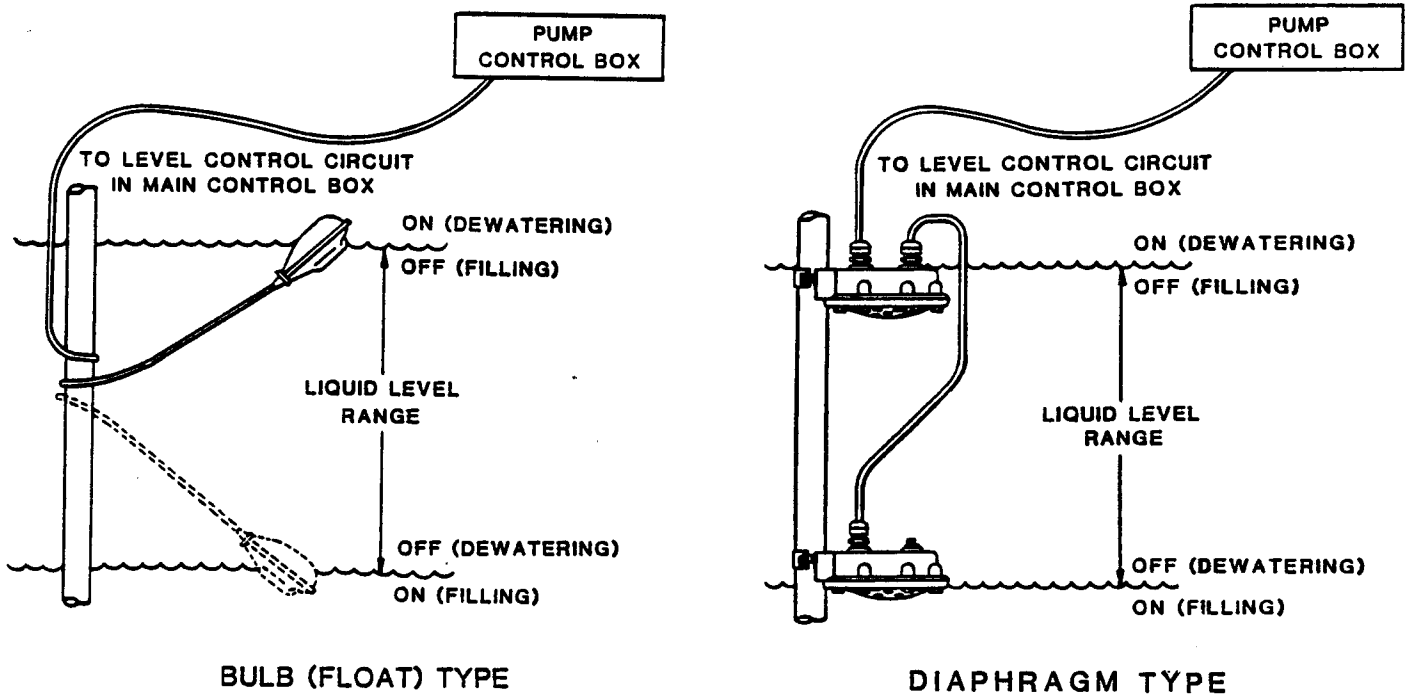
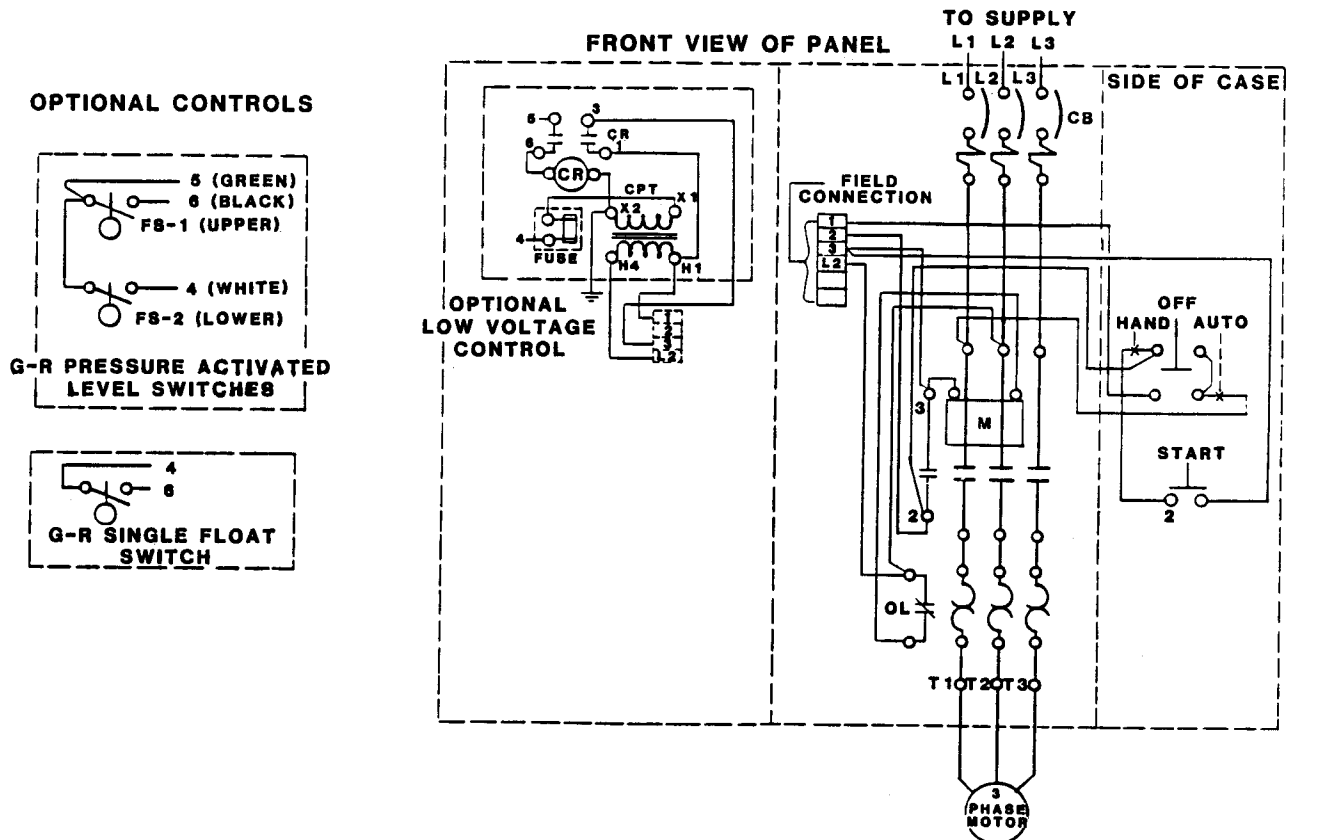

Figure 6. Liquid Level Devices

CAUTION

The internal wiring of the sensing devices are different for filling and dewatering functions. Be sure to follow the instructions included with the option before making wiring connections.

CONNECTION DIAGRAM



MOTOR DATA				OVERLOAD RELAY			CIRCUIT BREAKER			CONTROLLER			
HP	VOLTS 60 HZ	FLA	LRA	HEATER COIL	AMPERES		LRA TRIP TIME (SEC)	BREAKER AMPERE SIZE	TRIP CURRENT AMPS		GORMAN-RUPP PART NUMBER	FURNAS ELECTRIC NUMBER STYLE	GORMAN-RUPP MODEL
					HOLD	TRIP			LOCKING PIN POSITION	SETTING			
10	480	17	74	K57	16.9	17.8		30	150	120	27514-325	87DG302084	S4C1

Figure 7. Magnetic Controller Connection Diagram  
For Control Box 27514-325

ELEMENTARY DIAGRAM

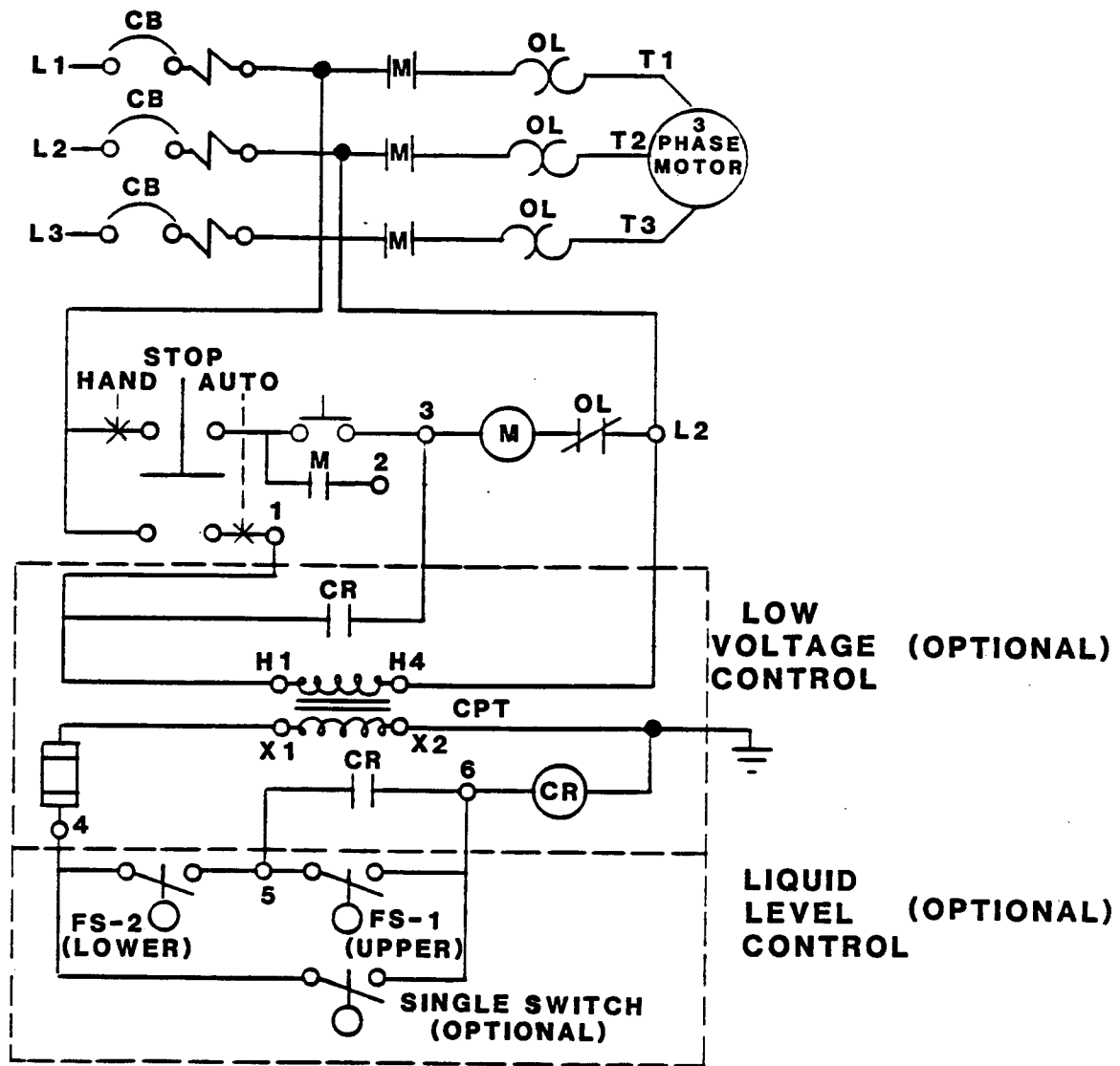

Figure 8. Magnetic Controller Elementary Diagram  
Based On Figure 7 on page B-14.

---



---

**REPAIR PARTS LIST, INTERNAL PARTS  
27514-325 CONTROL BOX ASSEMBLY**

(Repair Components Identified By Furnas Part Number)

PART NAME	PART NUMBER	MATL CODE	QTY
CIRCUIT BREAKER - 50 AMPS	D61025004	-----	1
CONTACTOR -3 POLE	40DP32A-H	-----	1
RENEWAL CONTACT SET	75DF14	-----	3
COIL	75D73070-H	-----	1
OVERLOAD RELAY	48DC38AA-3	-----	1
HEATER COIL	K57	-----	1
SELECTOR SWITCH	52SA2CABWJK	-----	1
START SWITCH	52-PA-8A1WK	-----	1



OPERATION

OPERATION - SECTION C

CONTROL BOX FUNCTION

WARNING

```

////////////////////////////////////
//
// This pump motor and control box are not designed to be //
// explosion proof. Do not operate in an explosive atmos- //
// phere. //
// //
////////////////////////////////////

```

A control box is provided to facilitate operation of the pump. It contains controls for starting and stopping the pump, and provides overload protection for the pump motor. The pump control may be equipped with an optional automatic liquid level sensing device, in which case the low voltage circuits are also contained within the control box.

WARNING

```

////////////////////////////////////
//
// The pump motor is designed to be operated through the //
// control box furnished with the pump. The control box //
// provides overload protection and power control. Do not //
// connect the pump motor directly to the incoming power //
// lines. //
// //
////////////////////////////////////

```

CAUTION

Since operation of the pump motor is dependent upon the quality and performance of the electrical controls, the pump warranty is valid only when controls have been specified or provided by the Gorman-Rupp Company.

Component Function

The control box contains the following hand operated switches and controls:

- The **control handle** operates the control box circuit breakers. In the OFF position, the control handle opens the circuit breakers to interrupt incoming power through the control box and prevent pump operation. In the ON position, it closes the circuit breakers to permit pump operation. The circuit breakers will open or "TRIP" automatically in the event of a short circuit overload current, or thermal excess within the pump motor or electrical system. When tripped, move the control handle to OFF and back to ON to reset the circuit breakers.

- The **selector switch** (optional on some boxes) controls the mode of operation. In the OFF position, it prevents all operation of the pump. In the HAND position, it allows the pump to run continuously. In the AUTO position, it allows the pump to be controlled automatically by the optional liquid level control system, if used.
- The **RESET** pushbutton resets the motor overload relay after it has been "TRIPPED" by an overload. The overload relay will trip automatically if the current drawn by the motor exceeds design specifications.

**NOTE**

If the overload unit trips, do not reset it immediately. Wait at least ten minutes before resetting the control handle back to the ON position. If the overload unit continues to trip, operational problems exist. See TROUBLESHOOTING.

**WARNING**

```

////////////////////////////////////
//
// The motor will restart as soon as the RESET pushbutton //
// is pressed, unless the selector switch is in the OFF po- //
// sition. Turn the selector switch to OFF and move the //
// control handle to OFF before approaching the pump. //
//
////////////////////////////////////

```

- The **liquid level devices** (optional equipment) operate in conjunction with the 3-position switch (HAND-OFF-AUTO) supplied as a part of that option. After the level sensors and circuitry have been installed, pump operation may be automatically controlled for filling or dewatering functions. (See LIQUID LEVEL DEVICES, Section B.)

**PUMP OPERATION**

**WARNING**

```

////////////////////////////////////
//
// This pump is designed to handle most non-volatile and //
// non-flammable industrial chemical and pH resistance ma- //
// terials Do not attempt to pump liquids which may damage //
// the pump or endanger personnel as a result of pump fail- //
// ure. //
//
////////////////////////////////////

```

**Liquid Temperature And Overheating**

The **maximum** liquid temperature for this pump is 120°F. Do not apply it at a higher operating temperature.

OPERATION

Overheating can occur if the pump is misapplied, required to start repeatedly, or if the control box fails to provide adequate protection. Operating the pump against a closed discharge for extended period will also cause the pump to overheat.

If overheating does occur, stop the pump immediately and allow it to cool before servicing it. **Approach any overheated pump cautiously.**

**WARNING**

```

////////////////////////////////////
//
// Overheated pumps can cause severe burns and injury. If //
// overheating of the pump occurs: //
//
// 1. Stop the pump immediately. //
// 2. Allow the pump to cool. //
// 3. Refer to instructions in this manual before re- //
// starting the pump. //
//
////////////////////////////////////

```

**Checking Pump Rotation**

Check the direction of pump rotation before operation to ensure that the impeller is rotating in the correct direction.

Suspend the pump from the hoisting bail. Turn it on momentarily and note the direction of twist. For correct rotation and operation, the twist must be in the **counterclockwise** direction when viewed from the **top**.

**CAUTION**

<p>Secure the pump during rotation check to prevent coiling of the power cable.</p>
---

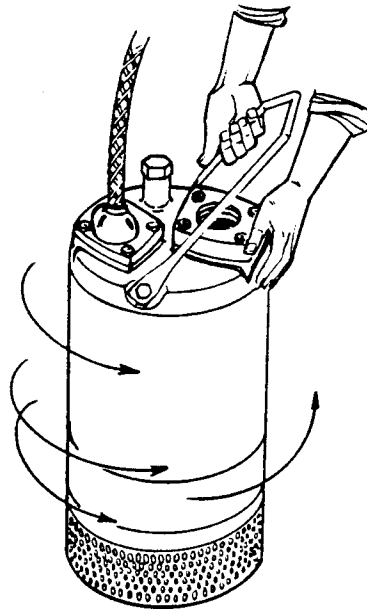

Figure 1. Checking Pump Rotation

If the pump twists clockwise on start, interchange any two motor leads at the control box.

**WARNING**

```

////////////////////////////////////
//                               //
// The electrical power used to operate this pump is high //
// enough to cause injury or death. Make certain that in- //
// coming power is OFF and LOCKED OUT before interchanging //
// motor leads.                                           //
//                               //
////////////////////////////////////

```

**STARTING**

After the pump and control box have been installed, start the pump as follows.

**NOTE**

Before actual operation, check the direction of impeller rotation to ensure that the pump is properly wired. See **Checking Pump Rotation** in **OPERATION** section.

## OPERATION

## CAUTION

Never start the pump more than 6 times per hour. If the motor does not cool between starts, it will overheat resulting in damage to the motor windings or control box components.

## Standard Pump (No Liquid Level Devices)

If no liquid level devices have been installed, move the control handle to the ON position and turn the selector switch to HAND. The pump motor will start and pumping should begin.

The pump will continue to operate until it is stopped by turning the selector switch to OFF.

## With Automatic Liquid Level Devices

If optional liquid level devices have been installed, move the 3-position selector switch to OFF and the control handle to the ON position.

If desired to operate the pump in the manual mode, set the selector switch to HAND; the pump will continue to run until the switch is returned to OFF, or reset to AUTO.

If desired to operate the pump in the automatic mode, set the selector switch to AUTO; pump operation will be maintained by the optional liquid level control system. To terminate automatic mode, move the selector switch to OFF or HAND.

## STOPPING

To stop pump operation, turn the control handle OFF.

Power through the control box may be terminated by moving the control handle to the OFF position, thereby opening the circuit breakers. This **does not** terminate incoming power through the field wiring connected to the control box.

After stopping the pump, be sure to perform all required maintenance and preservation procedures.

## NOTE

It is recommended that a check valve or throttling valve be installed in the discharge line if there is any possibility of siphoning or back flow when the pump is shut off.

OPERATION

Operation Checks

Check the pump for proper operation when it is first started and periodically thereafter to identify minor problems.

Check the pump for unusual noises or excessive vibration while it is operating. If noise or vibration is excessive, stop the pump and refer to the troubleshooting chart for possible causes.

Check the pump strainer screen for clogging caused by stones, sticks, or other debris. Clean the strainer screen when required. In some cases, stopping the pump momentarily may back flush the strainer screen, purging most of the debris from it. If this fails to clean the screen, remove the pump from the sump and remove the debris manually. See PUMP DISASSEMBLY.

**Never** introduce air or steam pressure into the pump casing or piping to remove a blockage. This could result in personal injury or damage to the equipment. If backflushing is absolutely necessary, **liquid pressure** must be limited to 50% of the maximum permissible operating pressure shown on the pump performance curve.

Check the pump for overheating. The pump could overheat if operated against a closed discharge valve, or subjected to repeated start cycles.

Cold Weather Preservation

In freezing temperatures, the pump will not freeze as long as it is submerged in liquid. If the pump casing is not submerged, or if the liquid begins to freeze, remove the pump from the sump or wet well and allow it to dry thoroughly. Run the pump for two or three minutes to dry the inner walls.

If the pump freezes, move it into a warm area until completely thawed, or submerge it into the liquid. If the liquid is near freezing, the pump must be submerged for an extended period of time. Start the pump and check for shaft rotation. If still frozen, allow additional thawing time before attempting to restart.

WARNING

```

////////////////////////////////////
//                               //
// Do not attempt to thaw the pump by using a torch or oth- //
// er source of flame. This could damage gaskets or heat //
// the oil within the pump above the critical point and //
// cause the pump to rupture or explode. //
//                               //
////////////////////////////////////

```



TROUBLE	POSSIBLE CAUSE	PROBABLE REMEDY
PUMP FAILS TO START, OVERLOAD UNIT NOT TRIPPED (AUTOMATIC MODE) (cont.)	<p>Float type sensing device(s) tangled or obstructed.</p> <p>Defective liquid level sensing device(s) or control panel.</p>	<p>Check installation for free movement of float.</p> <p>Repair or replace defective unit(s).</p>
OVERLOAD UNIT TRIPS	<p>Low or high voltage, or excessive voltage drop between pump and control box.</p> <p>Defective insulation in motor windings or power cable; defective windings.</p> <p>Impeller jammed due to debris or insufficient clearance.</p> <p>Bearing(s) frozen.</p> <p>Terminal housing incorrectly wired. (Dual voltage or single phase motors only).</p>	<p>Measure voltage at control box. Check that wiring is correct type, size, and length. (See Field Wiring Connection, Section B).</p> <p>Check insulation resistance; check continuity.</p> <p>Disassemble pump and check impeller.</p> <p>Disassemble pump and check bearing(s).</p> <p>Check terminal housing internal connections against motor wiring plate and schematic wiring diagram.</p>
MOTOR RUNS, BUT PUMP FAILS TO DELIVER RATED DISCHARGE	<p>Discharge head too high.</p> <p>Low or incorrect voltage.</p> <p>Discharge throttling valve partially closed; check valve installed improperly.</p> <p>Discharge line clogged or restricted; hose kinked.</p> <p>Liquid being pumped too thick.</p> <p>Strainer screen or impeller clogged.</p>	<p>Reduce discharge head, or install staging adaptor and additional pump.</p> <p>Measure control box voltage, both when pump is running and when shut off.</p> <p>Open discharge valve fully; check piping installation.</p> <p>Check discharge lines; straighten hose.</p> <p>Dilute liquid if possible.</p> <p>Clear clog(s). Stop pump; back flow may flush away debris.</p>



TROUBLE	POSSIBLE CAUSE	PROBABLE REMEDY
MOTOR RUNS, BUT PUMP FAILS TO DELIVER RATED DISCHARGE (cont.)	Insufficient liquid in sump or tank.  Worn impeller vanes; excessive impeller clear- ance.  Pump running backwards.	Stop pump until liquid level rises.  Check impeller and clearance. See PUMP END REASSEMBLY.  Check direction of rotation and correct by interchanging any two motor leads at control box. (See Pump Rotation, Section C).
PUMP RUNS WITH EXCES- SIVE NOISE OR VIBRATION	Pumping entrained air.  Damaged or unbalanced impeller.  Discharge piping not properly supported.  Impeller jammed or loose.  Motor shaft or bearings defective.  Pump cavitation.	Check liquid level in sump; check position of pump and liquid level sensing device(s).  Replace impeller.  Check piping installation.  Check impeller.  Disassemble pump and check motor and bearings.  Reduce discharge head, or restrict flow on low head appli- cations.

ELECTRICAL TESTING

If you suspect that pump malfunctions are caused by defects in the motor, power cable or control box, perform the following checks to help isolate the defective part.

WARNING

```

////////////////////////////////////
//
// The electrical power used to operate this pump is high //
// enough to cause injury or death. Obtain the services of //
// a qualified electrician to troubleshoot, test and/or //
// service the electrical components of this pump. //
//
////////////////////////////////////

```

CAUTION

<p>Be certain to refer to the wiring diagram(s) in the INSTALLATION section of this manual before reconnecting any electrical components which have been disconnected.</p>
--

Test Equipment

A volt/amp/ohmmeter and megohmmeter of adequate range and quality will be required to conduct the following electrical tests. The suggested equipment indicated below is commercially available, or an equivalent substitute may be used.

Equipment	Manufacturer	Use
Amprobe Model 300 or Amprobe, Jr.	Pyramid Instrument Corp. Lynbrook, NY	To check AC Voltage and current (amperage)
Megohmmer	Herman H. Sticht Co. 25 Bark Place New York, N.Y.	To measure resistance (ohms) to ground

Voltage Imbalance

Each phase of the incoming three-phase power must be balanced with the other two as accurately as a commercial voltmeter will read. If the phases are balanced, check out the motor as described below. If the phases are out of balance, contact your power company and request that they correct the condition.

## TROUBLESHOOTING

- 
- 
- a. Use a voltmeter, Amprobe, or equivalent meter to read the voltage across terminals 1 & 2, 2 & 3, and 1 & 3. in the control box. All three measured voltages must be the same, as accurately as the meter will read. If possible, measure the voltage with the pump off, with the pump running but out of the water, and with the pump running in the water at full load. All the measured voltages at each condition must be the same.
  - b. Use an Amprobe or equivalent meter to measure the current draw of each phase while the pump is running at full load and at no load. All three amperage readings must be the same at each condition, as accurately as the meter will read. Nominal amperage values are listed in Table 1, but these apply only when the actual voltage at the site is the nominal voltage listed.
  - c. If the voltages are balanced with the pump off, but are unbalanced when the pump is running, a thorough check of the power source, all interconnecting cables, and the pump motor is required to isolate the defect.

### Motor And Motor Power Cable Continuity

To check continuity, zero-balance the ohmmeter set at the RX1 scale, and test as follows:

- a. Disconnect the motor power cable leads from the control box and connect the test leads to any two of the three power cable leads (not to the green ground lead or yellow ground check lead). If there is a high resistance reading on the ohmmeter, there is an open or broken circuit caused by a break in the power cable or motor windings, or by a bad connection between the motor and the power cable. Switch one test lead to the third power lead, and test again.
- b. If an open or broken circuit is indicated, check the power cable for obvious damage, and replace as necessary (see **MAINTENANCE AND REPAIR**). If there is no apparent damage to the motor cable, remove the terminal housing (see **MAINTENANCE AND REPAIR**) and check the continuity of each power cable lead at the terminal posts.
- c. If an open circuit still exists after each lead (terminal) has been tested and tightened, then the **entire** motor power cable must be replaced. Splicing or other means of repair are not recommended.
- d. If no break is found in the power cable, check the motor leads for continuity. If the test reading indicates an open or broken circuit, there is an open circuit in the motor.

### NOTE

It is recommended that a pump with a defective motor be returned to Gorman-Rupp, or to one of the Gorman-Rupp authorized Submersible Repair Centers.

---

---

### Insulation Resistance

To check insulation, zero-balance the ohmmeter set at the RX100K scale, and test as follows:

- a. Disconnect the motor power cable leads from the control box. Connect one test lead to the power cable green ground lead, and touch the other test lead to each of the three power leads in turn.
- b. The reading obtained will indicate resistance values in both the power cable and the motor windings. If the resistance reading is infinity ( $\infty$ ), the insulation is in good condition. If the reading is between infinity ( $\infty$ ) and 1 megohm, the insulation is acceptable but should be rechecked periodically. If the reading is less than 1 megohm, the insulation should be checked more closely; a reading of zero indicates that the power cable or the motor is grounded.
- c. To determine whether the power cable or the motor is grounded, remove the terminal housing (see **MAINTENANCE AND REPAIR**), disconnect the motor leads from the motor terminals, and test the power cable leads and motor leads separately.

MAINTENANCE AND REPAIR - SECTION E

MAINTENANCE AND REPAIR OF THE WEARING PARTS OF THE PUMP WILL MAINTAIN PEAK OPERATING PERFORMANCE.

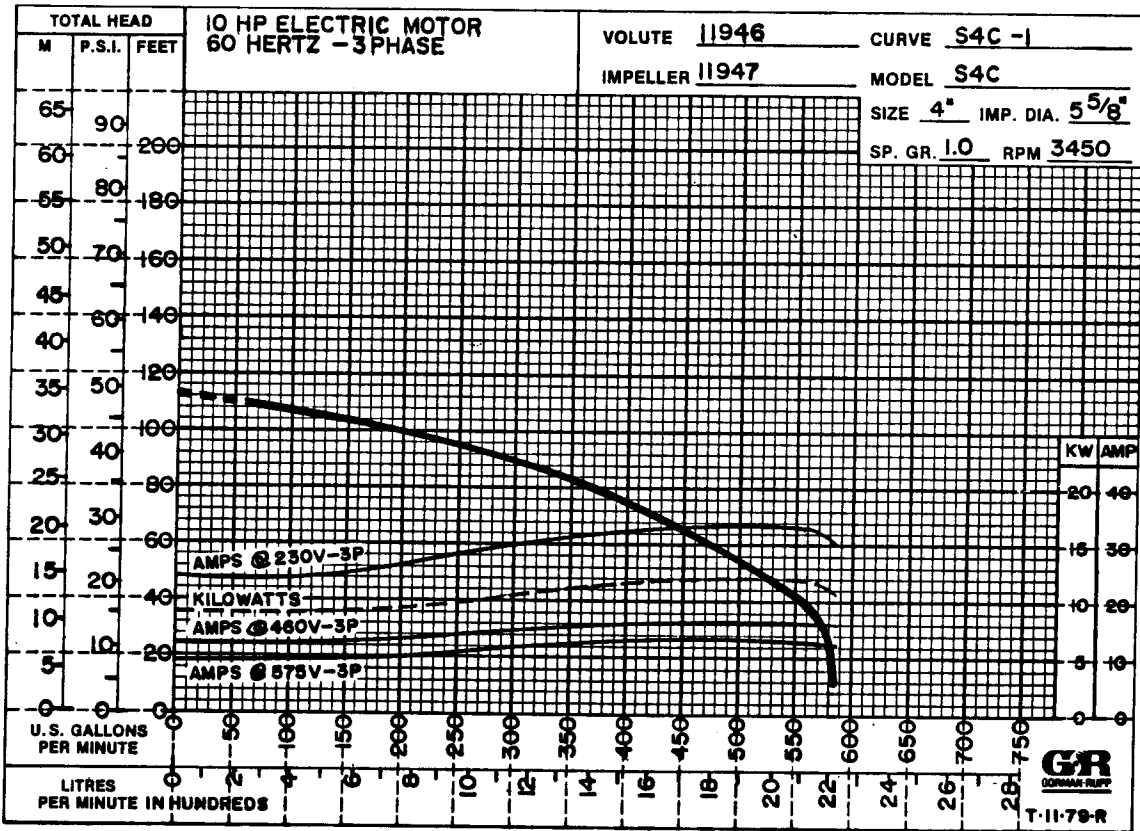

\*STANDARD PERFORMANCE FOR PUMP MODEL S4D65-E10 460V 3P

\*Based on 70°F clear water at sea level. Since pump installations are seldom identical, your performance may be different due to such factors as viscosity, specific gravity, elevation, temperature, and impeller trim.

If your pump serial number is followed by an "N", your pump is NOT a standard production model. Contact the Gorman-Rupp Company to verify performance or part numbers.

SECTIONAL DRAWING

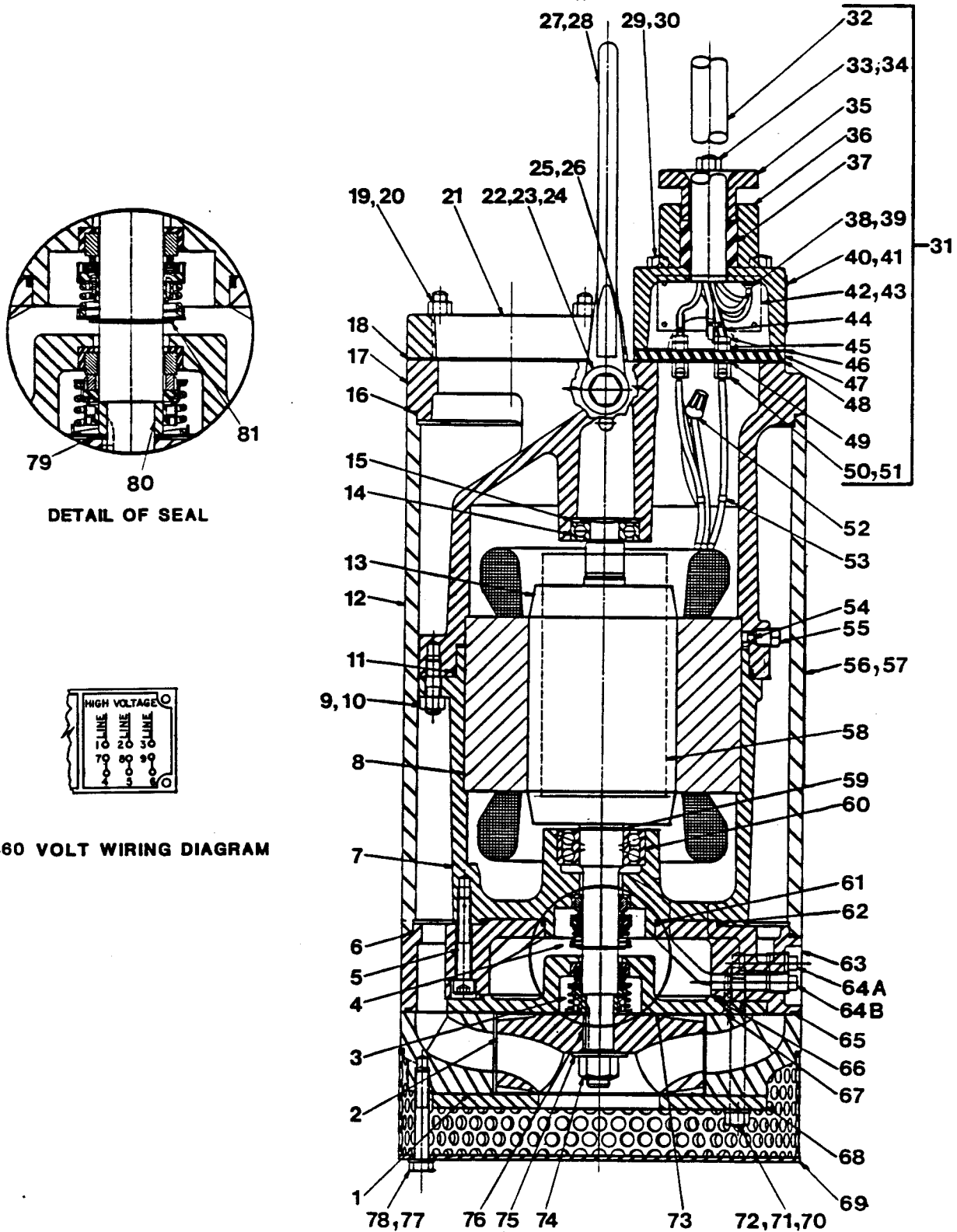

Figure 1. Pump Model S4D65-E10 460V 3P

**PARTS LIST**  
**Pump Model S4D65-E10 460V 3P**  
 (From S/N 853100 up)

If your pump serial number is followed by an "N", your pump is NOT a standard production model. Contact the Gorman-Rupp Company to verify part numbers.

ITEM NO.	PART NAME	PART NUMBER	MATL CODE	QTY	ITEM NO.	PART NAME	PART NUMBER	MATL CODE	QTY
1	DIFFUSER	11973	1718H	1	52	CONNECTOR	S01718	-----	3
2	*IMPELLER	11972	1718H	1	53	WIRE MARKER SET	S02274	-----	2
3	*LOWER SEAL ASSY	46512-070	-----	1	54	ALLEN HD SETSCREW	GA00501 1/4	17090	2
4	*UPPER SEAL ASSY	S01832	-----	1	55	PIPE PLUG	38649-022	17090	2
5	SOC HD CAPSCREW	DM00609	17090	3	56	NAME PLATE	38818-039	17090	1
6	*INTERMEDIATE O-RING	25154-274	-----	1	57	DRIVE SCREW	BM#04-03	17090	6
7	LOWER MOTOR HSG	38311-031	17070	1	58	INSTRUCTION TAG	6588-AJ	00000	1
8	STATOR ASSY	47113-803	-----	1	59	BRG SNAP RING	S01831	-----	1
9	STUD	C00606	17090	8	60	*LOWER BALL BRG	S01834	-----	1
10	DEFORM LOCKNUT	DD00006	17090	8	61	*INTERM O-RING	25154-234	-----	1
11	*MOTOR HSG O-RING	25154-265	-----	1	62	*INTERM O-RING	25154-259	-----	1
12	PUMP CASING	38311-807	17120	1	63	INTERMEDIATE	38261-025	17070	1
13	*ROTOR & SHAFT ASSY	47112-809	-----	1	64A	MOTOR CAVITY	P00004	17090	1
14	*UPPER BALL BRG	S01044	-----	1		DRAIN PLUG			
15	BRG SPRING WASHER	S01554	-----	1	64B	SEAL CAVITY	P00004	17090	1
16	*PUMP CASING O-RING	25154-274	-----	1		DRAIN/FILL PLUG			
17	*UPPER MOTOR HSG	38311-032	17070	1	65	*DIFFUSER O-RING	25154-274	-----	1
18	*DISCH FLANGE GSKT	11957-G	19370	1	66	*SEAL PLATE O-RING	25154-259	-----	1
19	DISCH FLANGE STUD	C00609	17090	4	67	FLAT HD MACH SCRW	Y#10-03	17090	3
20	HEX NUT	D00006	17090	4	68	*WEAR PLATE	11948-A	1718H	1
21	DISCH FLANGE	11957	17070	1	69	*STRAINER ASSY	11969	17050	1
22	FLAT WASHER	KE00008	17090	2	70	STUD	C00612	17090	3
23	LOCKWASHER	J00008	17090	2	71	LOCKWASHER	J00006	17090	3
24	HEX HD CAPSCREW	B00804	17090	2	72	HEX NUT	D00006	17090	3
25	SOC HD PIPE PLUG	PC00004	17090	1	73	SEAL PLATE	13882	1718H	1
26	REDUCING BUSHING	AP00604	17090	1	74	NYLOCK NUT	DD00010-S	17090	1
27	BUSHING	9562	17020	2	75	FLAT WASHER	KB00010	17090	1
28	HOISTING BAIL	11959	24170	1	76	*IMPELLER KEY	NO0303 1/2	17090	1
29	STUD	C00510	17090	4	77	LOCKWASHER	J00006	17090	3
30	HEX NUT	D00005	17090	4	78	HEX HD CAPSCREW	B00612	17090	3
31	TERMINAL HOUSING AND CABLE ASSY	47367-056	-----	1	79	*ADJ SHIM SET	2-Y	17090	1
32	*-POWER CABLE ASSY	47351-056	-----	1	80	*SHAFT SLEEVE	13878	17090	1
	-GRND TERMINAL	27214-243	-----	1	81	*SEAL RET RING	S00362	-----	1
	-GRND CHK TERM	S01836	-----	1		NOT SHOWN:			
	-LEAD TERMINAL	27214-243	-----	3		CABLE TIE	27111-212	-----	1
33	-STUD	C00606	17090	2		460/3 CONTROL BOX	27514-325	-----	1
34	-HEX NUT	D00006	17090	2		SUBMERSIBLE PUMP	9568	-----	1
35	-TERMINAL COLLAR	38381-625	17070	1		OIL - 1 QT			
36	-TERMINAL HOUSING	38381-232	17070	1		MOTOR VOLT TAG	38816-093	-----	1
37	*-CABLE BUSHING	10758-L	19540	1		OPTIONAL:			
38	-RD HD MACH SCREW	X#10-02	14990	2		230V CONTROL BOX	27514-324	-----	1
39	-T-TYPE LOCKWASHER	AK#00010	15991	2		REPAIR GASKET KIT	11000-AB	-----	1
40	-INFORMATION PLATE	38816-047	17050	1		STAGING ADAPTOR	13369	1718H	1
41	-DRIVE SCREW	BM#04-03	17090	4		ASSEMBLY			
42	-MOTOR PLATE	10436	17050	1		HEAT SHRINK TUBE	48315-006	-----	1
43	-DRIVE SCREW	BM#04-03	17090	4		AND ADHESIVE KIT			
44	*-HEAT SHRINK TUBE	31412-053	19530	3		TERM POTTING KIT	12442-B	-----	1
45	-HEX NUT	D#00010	14990	6		LIQUID LEVEL DEVICES:			
46	*-TERM PLATE GSKT	38687-525	19370	1		DIAPHRAGM TYPE	GRP48-03 or GRP48-06	1	
47	-TERMINAL PLATE	38713-008	23010	1		FLOAT TYPE	27471-155	-----	1
48	*-TERM PLATE GSKT	38687-525	19370	1		LOW VOLT CONTROL	S01657	-----	1
49	*-DYNA-SEAL WASHER	S01590	-----	3		- 24 VOLT			
50	-TERMINAL	11181	14100	3					
51	-NYLOCK MACH SCREW	XA#10-011/4S	14990	3					

\*INDICATES PARTS RECOMMENDED FOR STOCK

Above Serial Numbers Do Not Apply To Pumps Made In Canada.

CANADIAN SERIAL NO ..... AND UP

MAINTENANCE AND REPAIR

PUMP AND MOTOR DISASSEMBLY AND REASSEMBLY

The following maintenance and repair instructions are keyed to the sectional view (see Figure 1) and the accompanying parts list.

WARNING

```

////////////////////////////////////
//
// The electrical power to operate this pump is high enough //
// to cause injury or death. Make certain that the control //
// handle on the control box is in the OFF position and //
// locked, or that the power supply to the control box has //
// been otherwise cut off and locked out, before attempting //
// to open or service the pump assembly. Tag electrical //
// circuits to prevent accidental start-up. //
// //
////////////////////////////////////

```

Before attempting to service the pump or control, cut off the power supply to the control box and close any valves in the discharge line.

WARNING

```

////////////////////////////////////
//
// Do not attempt to lift the pump by the motor power cable //
// or the piping. Attach proper lifting equipment to the //
// hoisting bail fitted to the pump. If chains or cable //
// are wrapped around the pump to lift it, make certain //
// that they are positioned so as not to damage pump, and //
// so that the load will be balanced. //
// //
////////////////////////////////////

```

Use the hoisting bail to lift the pump from the wet well and move it to a location where the discharge line can be removed. It is not necessary to disconnect flexible discharge hose before removing the pump. If rigid discharge piping is used, disconnect the piping or the discharge flange (21) before attempting to remove the pump. To remove the discharge flange, disengage the nuts (20) and remove the flange and gasket (18) from the upper motor housing (17).

Select a suitable location, preferably indoors, to perform the degree of maintenance required. If the motor housing is to be opened, the work must be done in a clean, well-equipped shop. All maintenance functions must be performed by qualified personnel.

Check the chart in **TROUBLESHOOTING** to determine the nature of the pump problem. If the problem is mechanical in nature, such as worn pump parts, seal replacement, lubrication, etc., refer to **PUMP END DISASSEMBLY**. If the problem is electrical, complete disassembly of the pump may not be required. Refer to **Electrical Testing** and have a qualified electrician check out the control box, cable and terminal housing assembly. If the problem is determined to be in the motor, proceed with **PUMP END DISASSEMBLY** followed by **MOTOR DISASSEMBLY**.

All gaskets and most O-rings **must** be replaced if disturbed. A repair gasket kit is listed on the parts list as an option.



---

---

## PUMP END DISASSEMBLY

### Strainer Disassembly

To remove the strainer assembly (69), raise the pump slightly or lay it on its side and remove the hardware (77 and 78) securing the strainer to the diffuser (1). If the impeller is clogged, the debris can usually be removed without further disassembly.

### Draining Oil From Seal And Motor

After removing the strainer, the wear plate (68), diffuser (1) and impeller (2) may be serviced without draining the oil cavities. However, the oil should be drained before attempting to replace the shaft seals (3 and 4) or repair the motor.

#### CAUTION

Let the pump cool before removing the seal or motor cavity drain plug. Pressure built up within a hot pump could cause the oil to spray out when the plug is removed. Remove the plug slowly and permit pressure to vent to atmosphere.

Lay the pump on its side with the drain plugs (64A and 64B) facing up and clean any dirt from around the plugs. Remove the seal cavity drain plug (64B) and install a short 1/4-inch NPT nipple in the hole. Tip the pump up and drain the seal oil into a **clean** container. Inspect it for water, dirt or cloudy condition which could indicate lower seal failure or poor gasket seal.

If motor problems are suspected, remove the motor cavity drain plug (64A) and use a short nipple to drain the oil into a **clean** container at this time. Inspect the oil for dark color which could indicate motor overheating, dirt or water contamination. The presence of dirt or water could indicate a breakdown in the waterproof integrity of the motor cavity, probably due to poor gaskets or seals.

### Positioning Pump For Disassembly

It is recommended that the pump be positioned upside-down during disassembly. To hold the pump in an inverted position, secure the discharge flange studs (19) to a bench or work stand, or rest the pump securely on blocks. Be careful not to damage the terminal housing (36) or power cable (32) while the pump is in this position. Use adequate equipment and personnel to safely handle the pump until it is secured.

If inverting the pump is not practical, lay the pump on its side and secure it.

---

---

### Impeller Disassembly

For access to the impeller (2), remove the hardware (71 and 72) securing the wear plate (68) and diffuser (1) to the intermediate (63). Pull the wear plate and diffuser off the studs. Remove and discard the O-ring (65).

Wedge a piece of wood between the vanes of the impeller (2) and the intermediate studs (70) to prevent shaft rotation. Remove the impeller deform locknut (74) and impeller washer (75).

Remove the piece of wood from between the vanes of the impeller. Pry the impeller off the shaft using two screwdrivers as shown in Figure 2. Use caution when removing the impeller; tension on the seal spring will be released. Retain the impeller key (76).

Remove the impeller adjusting shims (79); for ease of reassembly, tie and tag the shims.

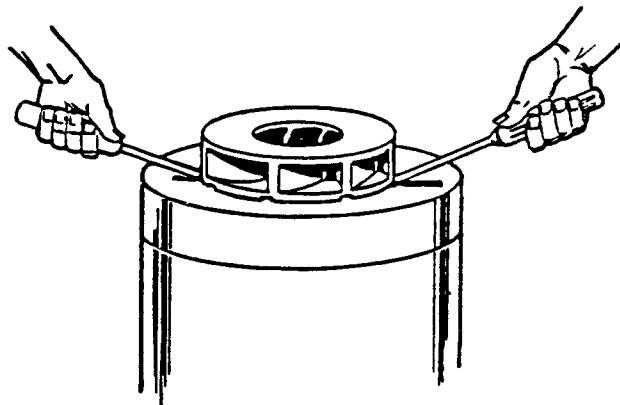

Figure 2. Removing Impeller

### Lower Seal Disassembly

#### (Figures 1 and 3)

Carefully remove the loose parts of the lower seal assembly (3). Use a stiff wire with a hooked end to pull the shaft sleeve (80) and rotating portion of the seal from the shaft. Lubricate the shaft sleeve adjacent to the seal, and work oil under the rubber bellows. Separate the sleeve from the rubber bellows.

To remove the stationary portion of the seal, remove the flat head machine screws (67) and separate the seal plate (73) from the intermediate (63). Remove and discard the seal plate O-ring (66). Place the seal plate on a flat surface with the impeller side down. Use a drift pin or screw driver to press on alternate sides of the stationary seat until removed.

The rotating and stationary seal elements are precision finished and subject to wear. The complete seal should be replaced with each overhaul to ensure trouble-free operation. However, if the old seal must be reused, wrap the seal faces individually in tissue paper to prevent damage to the sealing surfaces.

---

---

If no further disassembly is required, proceed to the appropriate areas in **PUMP END REASSEMBLY**.

### Upper Seal Disassembly

#### (Figures 1 and 3)

Unless cracked or otherwise worn, it is not necessary to remove the intermediate (63) for access to the upper seal assembly (4). If intermediate removal is desired, remove the socket head capscrews (5) securing it to the lower motor housing (7). Remove and discard the intermediate O-rings (6, 61 and 62).

Remove the seal retaining ring (81) with snap ring pliers. Use caution when removing the retaining ring; tension on the seal spring will be released. Remove the seal spring retainer and spring. Lubricate the rotor shaft adjacent to the seal, and work oil under the bellows. Use a stiff wire with a hooked end to pull the rotating portion of the seal off the shaft.

Slide the hooked ends of two wires along the shaft and under the stationary seal seat. Hook the back side of the seat and pull it from the intermediate.

#### NOTE

Do not disassemble the motor unless it is necessary and a clean, well-equipped shop is available. If the motor housing components are to be serviced, see **MOTOR DISASSEMBLY** in this section. Do not reassemble the pump end components at this time.

If no further disassembly is required, proceed to the appropriate areas in **PUMP END REASSEMBLY**.

### PUMP END REASSEMBLY

#### NOTE

Reuse of old O-rings, gaskets, or shaft seal parts may result in premature leakage or reduced pump performance. It is strongly recommended that an overhaul gasket kit and new shaft seal assemblies be used during reassembly (see the parts list for numbers).

### Cleaning Old Parts

With the pump inverted, stuff a clean tissue into the stationary seat bore of the lower motor housing (or wrap a small rag around the shaft) to prevent foreign material from entering the motor cavity.

MAINTENANCE AND REPAIR

Carefully inspect any O-rings or gaskets before removal and cleaning to determine if a proper seal and compression existed prior to disassembly. If sealing was faulty or questionable, the cause must be determined and corrected before reassembly. Replace any parts required.

Thoroughly clean all reuseable parts with a soft cloth soaked in cleaning solvent. Remove all O-rings and gaskets and clean the sealing surfaces of dirt or gasket material. Be careful not to scratch gasket surfaces.

WARNING

```

////////////////////////////////////
//
// Most cleaning solvents are toxic and flammable. Use //
// them only in a well-ventilated area free from excessive //
// heat, sparks, and flame. Read and follow all prec- //
// autions printed on solvent containers. //
// //
////////////////////////////////////

```

Neither of the shaft seal assemblies should be reused because wear patterns on the finished faces cannot be realigned during reassembly. This could result in premature failure. If necessary to reuse an old seal in an emergency, **carefully** wash all metallic parts in fresh cleaning solvent and allow to dry thoroughly.

Handle the seal parts with extreme care to prevent damage. Be careful not to contaminate precision finished faces; even fingerprints on the faces can shorten seal life. If necessary, clean the faces with a non-oil based solvent and a clean, lint-free tissue. Wipe **lightly** in a concentric pattern to avoid scratching the faces.

Inspect the seal components for wear, scoring, grooves, and other damage that might cause leakage. If any components are worn, replace the complete seal; **never mix old and new seal parts.**

Install the shaft seals as illustrated in Figure 3.

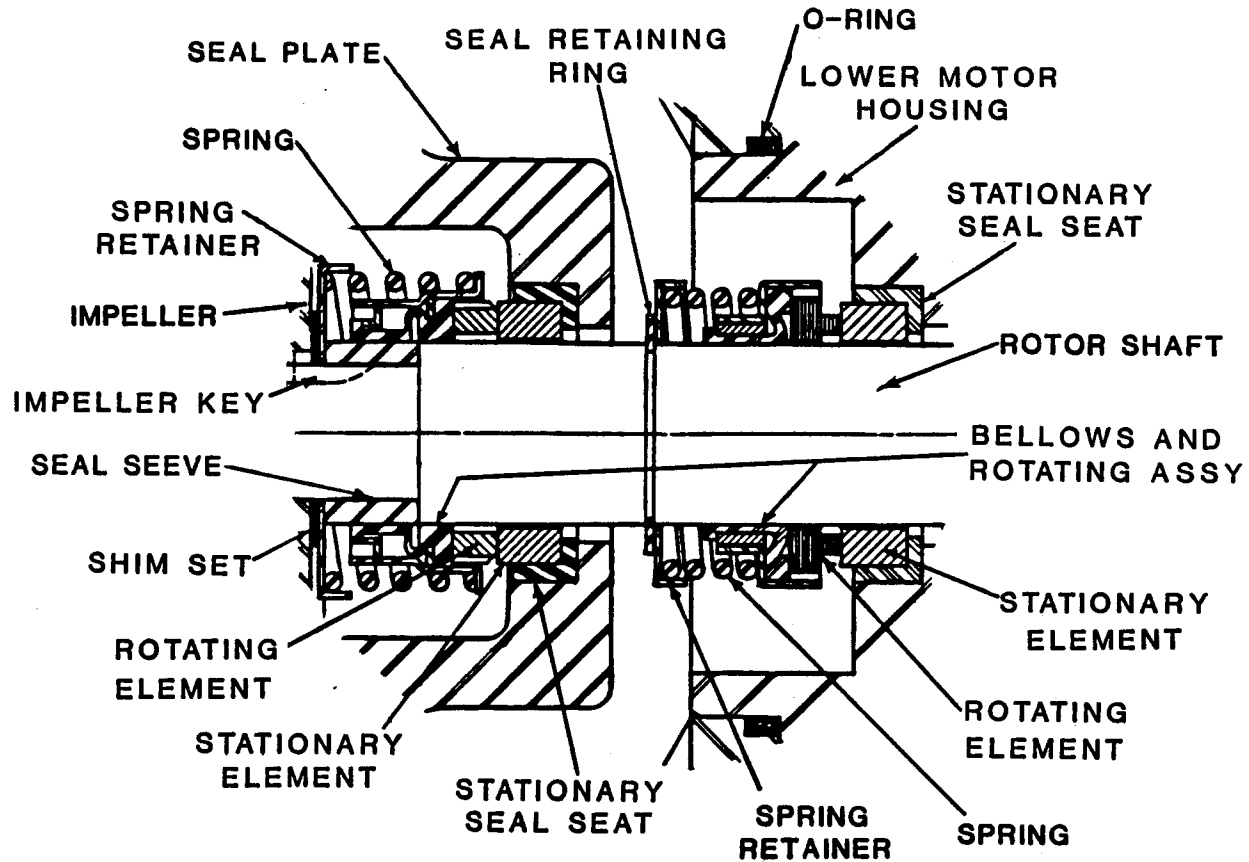

Figure 3. Seal Assemblies 46512-070 and S01832

### Upper Seal Reassembly

Inspect the end of the rotor shaft for damaged threads, scoring, and a nicked or damaged keyway. Remove nicks and burrs with a fine file or hand honing stone to restore original contours. If the shaft is bent or damaged, the complete shaft and rotor (13) must be replaced as an assembly (see **MOTOR DISASSEMBLY**).

If the intermediate (63) has been removed, replace the intermediate O-rings (6, 61 and 62), and position the intermediate on the lower motor housing (7). Coat the threads of the socket head capscrews (5) with 'Never-Seez' or equivalent compound, and install the capscrews through the intermediate and into the lower motor housing; torque the capscrews to 22 ft. lbs. (264 inch lbs.).

If a new seal is to be installed, do not unwrap it until time of installation. Cleanliness of all seal components is a must, especially the seal faces.

Carefully remove the material stuffed into the seat bore (or unwrap the shaft). Be sure no debris stopped by the material falls into the motor cavity.

Carefully clean the rotor shaft and seal bore in the intermediate (63). Check for burrs or nicks in the intermediate that might cut seal components or prevent a good seal. Apply a **light** coating of oil to the shaft and intermediate bore.

---

---

### NOTE

When pressing seal components onto the impeller shaft, use hand pressure only. A push tube cut from a length of plastic pipe will aid in installing seal components. The I.D. of the push tube should be approximately the same as the I.D. of the seal spring.

Unpack the stationary seat and element. Subassemble the two parts and place a clean tissue over the seal face. Use your fingers to press the seat and element into the bore. Apply equal pressure on opposite sides of the seat until the assembly bottoms against the bore shoulder. Remove the tissue and inspect the seal face to ensure that it is clean and dry. If cleaning is necessary, use a clean tissue to wipe lightly in a concentric pattern.

Unpack the rotating portion of the seal. Be certain the seal face of the rotating element is free of grit or surface damage. Place a **small** amount of grease at equal spaces on the back of the element and assemble the drive grooves of the rotating element into the drive lugs of the bellows retainer. The grease should hold the element in position until the seal is installed.

Apply a light coating of oil to the seal seating surface on the shaft, the groove for the retaining ring (81), and the I.D. of the bellows. Position the rotating seal portion on the shaft with the seal face down. Apply firm, steady pressure, with clean hands, on the seal retainer until it slides down the shaft and the seal faces contact. This step should be done in one continuous motion to prevent the bellows from sticking or rolling as it passes over the retaining ring groove.

Slide the seal spring over the bellows retainer, and install the spring retainer. Install the seal retaining ring (81). See Figure 3 for proper order of seal assembly.

### Lower Seal Reassembly

Thoroughly clean the gasket surfaces and seal bore of the seal plate (73). The seal bore must be free of burrs and nicks which could damage the seal.

### NOTE

When pressing seal components into the seal plate and onto the impeller shaft, use hand pressure only. A push tube cut from a length of plastic pipe will aid in installing seal components. The I.D. of the push tube should be approximately the same as the I.D. of the seal spring.

Unpack the stationary seat and element and subassemble the two parts. Apply a light coating of oil to the seal plate bore and the outside of the seal seat. Place a clean tissue over the sealing face, and use your fingers to press the seat and element into the seal bore. Apply equal pressure on opposite sides of the seat until the assembly bottoms against the bore shoulder. Remove the tissue and inspect the seal face to ensure that it is clean and dry. If cleaning is necessary, use clean tissue to wipe lightly in a concentric pattern.

Replace the seal plate O-ring (66). Carefully position the seal plate and stationary seal components on the rotor shaft and against the intermediate. **Be careful** not to damage the stationary seal element already installed. Secure the seal plate to the intermediate with the flat head machine screws (67).

Install the seal sleeve (80) with the chamfered end toward the shaft shoulder. Lubricate the O.D. with a light coating of oil.

Unpack the rotating portion of the seal. Be certain the seal face of the rotating element is free of grit or surface damage. Place a **small** amount of grease at equal spaces on the back of the element and assemble the drive grooves of the rotating element into the drive lugs of the bellows retainer. The grease should hold element in position until the seal is installed.

Apply a light coating of oil on the rotor shaft and I.D. of the bellows. Position the rotating seal portion on the shaft with the seal face down. Apply firm, steady pressure, with clean hands, on the seal retainer until it slides down the shaft and the seal faces contact.

Slide the seal spring over the bellows retainer, and install the spring retainer. See Figure 3 for proper order of seal assembly.

### Impeller Reassembly

Inspect the impeller (2), and replace it if cracked or worn.

Install the same thickness of impeller adjusting shims (79) as originally removed. Install the impeller key (76) in the rotor shaft keyway, align the impeller keyway, and press the impeller onto the shaft until it seats firmly against the adjusting shims.

For maximum pump efficiency, the impeller should be centered within the diffuser cavity.

To verify the impeller positioning, measure the diffuser and impeller as shown in Figure 4. Use these measurements to calculate the required impeller location (dimension E). Add or remove impeller adjusting shims until dimension E is obtained.

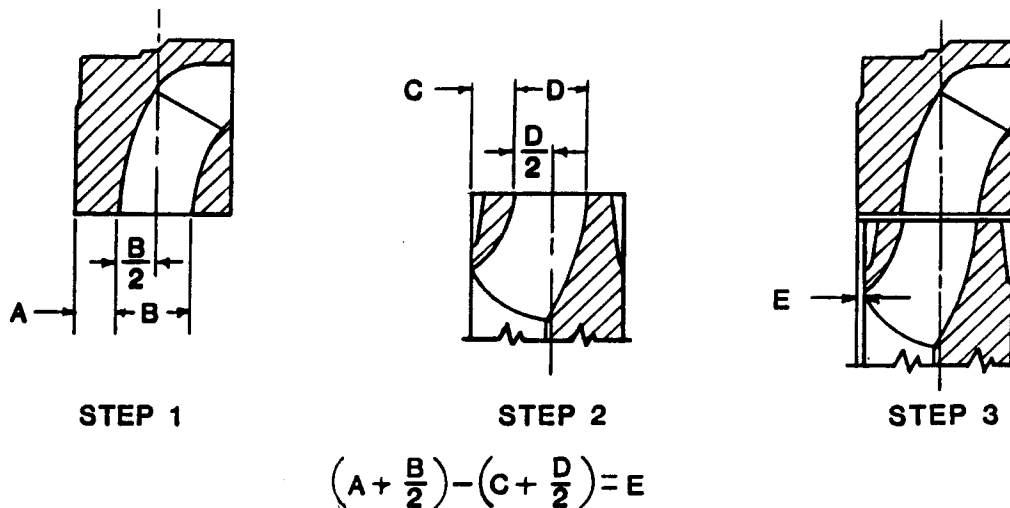

Figure 4. Centering Impeller Within Diffuser

---

---

### NOTE

After the impeller has been properly positioned, check for free rotation. Correct any scraping or binding before further reassembly.

After the impeller has been installed, coat the threads of the rotor shaft with 'Never-Seez' or equivalent compound. Install the impeller flat washer (75) and deform locknut (74). Place a block of wood between the vanes of the impeller to prevent shaft rotation, and torque the nylock nut to 120 ft. lbs. (1440 inch lbs.).

### Diffuser, Wear Plate And Screen Reassembly

Thoroughly clean the diffuser (1) and its O-ring surfaces. Replace the O-ring (65), and install it in the groove in the intermediate (63).

Inspect the wear plate (68). If one side is eroded, flip it over and install the smooth side next to the impeller. Replace the wear plate if both sides are badly scored or worn.

Carefully position the diffuser and wear plate over the studs (70) in the intermediate (63), and secure them with the hardware (71 and 72). After installing the diffuser and wear ring, check the impeller for free rotation.

Carefully position the strainer (69) on the diffuser (1), and secure it with the hardware (77 and 78). Make certain that the strainer seats properly against the shoulder of the diffuser.

### MOTOR DISASSEMBLY

Disassembly of the motor is rarely required except to replace the motor rotor, stator, bearings, or intermediate. Do not disassemble the motor unless it is necessary and a clean, well-equipped shop is available.

### NOTE

It is recommended that a pump with a defective motor be returned to Gorman-Rupp, or to one of the Gorman-Rupp authorized Submersible Repair Centers.



MAINTENANCE AND REPAIR

WARNING

```

////////////////////////////////////
//
// The electrical power to operate this pump is high enough //
// to cause injury or death. Make certain that the control //
// handle on the control box is in the OFF position and //
// locked, or that the power supply to the control box has //
// been otherwise cut off and locked out, before attempting //
// to open or service the pump assembly. Tag electrical //
// circuits to prevent accidental start-up. //
// //
////////////////////////////////////

```

Carefully inspect any O-rings or gaskets before removal and cleaning to determine if a proper seal and compression existed prior to disassembly. If sealing was faulty or questionable, the cause must be determined and corrected before reassembly. Replace any parts as required.

Terminal Housing And Power Cable Disassembly

If the pump is maintained in an upright position, the terminal housing and power cable assembly (31) may be serviced without draining the oil from the motor cavity. However, the oil must be drained before attempting to disassemble the motor housings (7 and 17) and components. To drain the oil, see **Draining Oil From Seal And Motor** in **PUMP END DISASSEMBLY**.

Total disassembly of the terminal housing and power cable is not always required. Disassemble and replace **only** the parts proven defective by inspection or testing. See **Electrical Testing** in **TROUBLESHOOTING**.

The terminal housing and power cable assembly (31) may be serviced without disassembling the motor housing or pump end. To remove the terminal housing (36), remove the nuts (30) securing the terminal housing to the upper motor housing (17). Raise the terminal housing and terminal plate for access to the motor terminal posts (50). Loosen the machine screws (51) and disconnect the motor leads from the terminal posts. Remove the terminal housing and power cable assembly.

To separate the power cable (32) from the terminal housing, remove the nuts (34) securing the terminal gland (35) to the terminal housing. Slide the gland back along power cable. Oil the gland bushing (37) and terminal housing bore and pull firmly on the cable. (Allow the oil to leak in around the bushing by agitating the cable in the bore.) After the bushing has been loosened, the cable should pull out far enough to expose the gland bushing. Apply oil on the cable jacket and slide the bushing back along the cable. Quite often, pressure exerted on the bushing will deform the cable jacket. If such is the case, additional oil and effort will be required to remove the bushing.

NOTE

If the rubber bushing cannot be removed from the terminal housing as indicated, it may be necessary to cut the bushing into small pieces or cut the cable.

---

---

Push approximately 6 inches of the power cable into the terminal housing so that the terminal plate (47) comes free of the terminal housing. This should permit access to the power cable connections in the terminal plate.

To disconnect the power cable, remove the round head screws and lockwashers (38 and 39) securing the green ground lead and yellow ground check lead. When shipped from the factory, the connections between the power cable leads and the terminals were encapsulated in heat-shrink tubing (44) and bonded to the terminal plate (47) with hot-melt adhesive. (In service, the heat-shrink tubing may have been replaced by potting compound during previous repair.) Carefully cut away the adhesive (or potting) and remove the upper nuts (45). Disconnect the power cable leads from the terminals posts.

Pull the power cable out of the terminal housing. The gland bushing (37) and terminal gland (35) can be removed from the cable.

It is not necessary to remove the heat-shrink tubing from the power cable leads unless the terminals require replacement. If replacement is required, carefully cut the tubing from around the leads and terminals.

If necessary to replace the terminal plate (47), unscrew the lower nuts (45) from the terminal posts (50) and remove the posts and dyna-seal washers (49) from the terminal plate. Discard the terminal plate gaskets (46 and 48).

See **Terminal Housing And Power Cable Reassembly** if no further disassembly is required.

### **Pump Casing And Motor Housing Disassembly**

See **PUMP END DISASSEMBLY** and remove all pump end and seal components.

With the pump end disassembled and the motor cavity drained, secure the pump in an inverted position.

If the intermediate (63) was not removed at **Upper Seal Disassembly**, disengage the flat head machine screws (67) and remove the intermediate, O-rings (6, 61 and 62) at this time. Slide the pump casing (12) off the upper motor housing (17) and remove the O-ring (16).

Remove the deformed locknuts (10), and separate the lower motor housing (7) from the upper motor housing (17). If necessary, pry the housings apart using two screwdrivers as shown in Figure 5. When the motor housings separate, remove the motor housing O-ring (11).

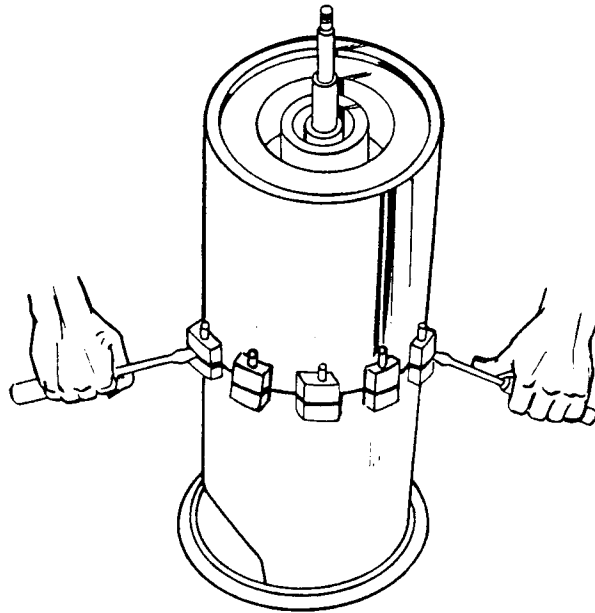

Figure 5. Separating Upper And Lower Motor Housings

### Rotor Disassembly

Carefully pull the shaft and rotor (13) and the assembled ball bearings (14 and 60) from the stator. Handle the rotor carefully to prevent it from falling on the stator windings. With the rotor removed, reach into the upper housing and remove the wavy spring washer (15) from the bearing bore.

Use a bearing puller to remove the lower and upper ball bearings from the rotor shaft. It is not necessary to remove the snap ring (59) from the shaft unless replacement is required. Use snap ring pliers to remove the ring.

### Stator Disassembly

It is recommended that the stator (8) be left in place unless it is defective. If the stator must be removed, disconnect the motor leads from the terminals (50) as indicated in **Terminal Housing And Power Cable Disassembly**.

Remove the pipe plugs (55) located in the upper motor housing, and loosen the allen head setscrews (54) located underneath the pipe plugs.

Position an expandable tool, such as a split disc, approximately 2 inches down inside the stator, and expand it tightly and squarely on the I.D. Attach a lifting device to the lifting eye of the tool and raise the assembly approximately one inch off the work surface. Take care not to damage the stator end turns. Use a soft-faced mallet to rap alternate edges of the upper motor housing (17), and "walk" the stator out. Continue this process until the stator clears the motor housing.

**NOTE**

It may be necessary to heat the motor housing to permit stator removal.

After the stator has been removed, wrap it in clean dry rags or other suitable material. The stator **must** be kept clean and dry. When handling the stator, do not set it on the end windings; lay it on its side.

**CAUTION**

Do not attempt to rewind the stator. Winding tolerances and materials are closely controlled by the manufacturer, and any deviation can cause damage or operating problems. Replace the stator, or return it to one of The Gorman-Rupp Authorized Submersible Repair Centers or The Gorman-Rupp factory, if defective.

**Hoisting Bail**

If the hoisting bail (28) requires replacement, remove the hardware (22, 23, and 24) securing the bail to the upper motor housing (17). Make certain that the bushing (27) is in place when installing the hoisting bail.

**MOTOR REASSEMBLY**

**WARNING**

////////////////////////////////////  
//  
// Refer to the wiring diagrams in INSTALLATION when recon- //  
// necting motor and power cable leads. //  
//  
////////////////////////////////////

**NOTE**

Reuse of old O-rings, gaskets, or shaft seal parts may result in premature leakage or reduced pump performance. It is strongly recommended that an overhaul gasket kit and new shaft seal assemblies be used during reassembly (see the parts list for numbers).

MAINTENANCE AND REPAIR

Stator Reassembly

Clean all gasket and O-ring surfaces completely, removing any old gasket and cement material. Inspect the sealing surfaces for burrs, nicks, and pits which could cause a poor seal, and replace defective parts as required.

Thoroughly clean the inside of the upper motor housing (17) with fresh solvent. The interior must be dry and free of dirt or lint.

WARNING

```

////////////////////////////////////
//
// Most cleaning solvents are toxic and flammable. Use //
// them only in a well-ventilated area free from excessive //
// heat, sparks, and flame. Read and follow all prec- //
// autions printed on solvent containers. //
// //
////////////////////////////////////

```

Do not unwrap the stator until the motor housing has been prepared for stator installation. The stator must be kept clean and dry. When handling the stator, do not set it on its end windings; lay it on its side.

Test the stator as indicated in **Electrical Testing** in **TROUBLESHOOTING** to ensure that no damage has occurred during handling.

Position an expandable tool, such as a split disc, approximately 2 inches down inside the stator, and expand the tool tightly and squarely on the I.D. Attach a lifting device to the lifting eye of the tool and carefully lift the assembly. Take care not to damage the stator end turns. Slip a sleeve over the stator lead wires to prevent damage to them.

With the upper motor housing in an inverted position, position the stator so that the leads are in line with the opening for the terminal housing, and carefully lower the stator into the motor housing. If the stator "cocks" in the motor housing, remove it and try again. If necessary, heat the upper motor housing with a torch to expand it enough for the stator to be installed; when heating the motor housing, make certain that the stator is clear to avoid damage to the windings. Apply heat evenly to the inside of the motor housing; excessive heat is not required. Be careful not to damage the stator lead insulation during reassembly.

After the stator is fully and squarely seated on the upper motor housing shoulder, remove the expandable disc tool. Install the allen head setscrews (54) securing the stator in place; torque the setscrews to 7.5 ft. lbs. (90 inch lbs.). Coat the threads of the pipe plugs (55) with 'Loctite Pipe Sealant With Teflon No. 592' or equivalent, and install the plugs over the allen head setscrews.

Cover the motor housing with a clean, lint-free cloth while the rotor is being assembled.

Rotor Reassembly

Inspect the seal and bearing areas of the shaft. Inspect the shaft for damaged threads, scoring and a nicked or damaged keyway. Remove nicks and burrs with a

MAINTENANCE AND REPAIR

fine file or honing stone. If the shaft is bent or damaged, replace the shaft and rotor (a single assembly).

Clean the bearings thoroughly in **fresh** cleaning solvent. Dry the bearings with filtered compressed air and coat with light oil.

**WARNING**

```

////////////////////////////////////
//
// Most cleaning solvents are toxic and flammable. Use //
// them only in a well-ventilated area free from excessive //
// heat, sparks, and flame. Read and follow all prec- //
// autions printed on solvent containers. //
// //
////////////////////////////////////

```

Rotate the bearings by hand to check for roughness or binding and inspect the bearing balls. If rotation is rough or the bearing balls are discolored, replace the bearings.

**CAUTION**

Bearings must be kept free of all dirt and foreign material. Failure to do so will greatly shorten bearing life. DO NOT spin dry bearings. This may scratch the balls or races and cause premature bearing failure.

The bearing tolerances provide a tight press fit onto the shaft and a snug slip fit into the upper motor housing and intermediate. Replace the shaft and rotor (as an assembly), upper motor housing or intermediate if the proper bearing fit is not achieved.

If removed, install the lower bearing snap ring (59) on the rotor shaft. Position the lower ball bearing (60) on the shaft with the loading groove facing **away** from the impeller end of the shaft. Use an arbor (or hydraulic) press to install the bearing on the shaft until fully seated against the snap ring.

**CAUTION**

When installing the bearings onto the shaft, NEVER press or hit against the outer race, balls, or ball cage. Press **ONLY** on the inner race.

Press the upper ball bearing (14) onto the rotor shaft until fully seated against the shaft shoulder.

Clean the bore of the upper motor housing (17), and install the spring washer (15) in the bore.

Carefully lower the assembled rotor shaft and bearings through the stator until the upper ball bearing seats squarely in the upper motor housing bore.

Motor Housing And Pump Casing Reassembly

Use solvent to clean both bores and all O-rings surfaces of the lower motor housing (7), completely removing any old gasket and cement material. Inspect the sealing surfaces for burrs, nicks and pits which could cause a poor seal, and repair or replace as required.

WARNING

Warning text enclosed in slashes: Most cleaning solvents are toxic and flammable. Use them only in a well-ventilated area free from excessive heat, sparks, and flame. Read and follow all precautions printed on solvent containers.

Replace the motor housing O-ring (11). Position the lower motor housing (7) down over the stator, rotor shaft and assembled bearings so that it seats squarely against the upper motor housing (17). Be careful not to cut the motor housing O-ring.

Coat the upper motor housing studs (9) with 'Never-Seez' or equivalent compound, and secure the upper and lower motor housings with the deformed locknuts (10); torque the locknuts to 20 ft. lbs. (240 inch lbs.).

Clean the sealing surfaces at each end of the pump casing (12), replace the O-ring (16), and slide the pump casing into position around the motor housings.

Install the gaskets and O-rings (6, 61 and 62) and position the intermediate (63) against the pump casing and lower motor housing. Be careful not to damage the gaskets or O-ring. Apply 'Never-Seez' or equivalent to the threads, and torque the socket head capscrews (5) to 22 ft. lbs. (264 inch lbs.).

See PUMP END REASSEMBLY, and reassemble the pump end components.

Terminal Housing And Power Cable Reassembly

WARNING

Warning text enclosed in slashes: The electrical power used to operate this pump is high enough to cause injury or death. Make certain that the control handle on the control box is in the OFF position and locked, or that the power supply to the control box has been otherwise cut off and locked out. Tag electrical circuits to prevent accidental start-up. Obtain the services of a qualified electrician and refer to the wiring diagrams in INSTALLATION to make all electrical connections.

Clean the exterior of the pump power cable with warm water and mild detergent, and check for obvious physical damage. Check the cable for continuity and insulation resistance (see **Electrical Testing** in TROUBLESHOOTING).

**CAUTION**

Do not attempt repairs except at either end of the power cable. Splicing is not recommended.

Lubricate the upper bore of the terminal housing (36), outside of the power cable (32), and bores of the terminal gland (35) and gland bushing (37) for ease of assembly. Slide the terminal gland bushing and terminal housing onto the power cable in that order (see Figure 1 to recheck order of assembly).

Work the cable components up the cable to allow approximately 3 ft. of cable to extend below the terminal housing. Temporarily tape the green and yellow ground wires to the cable.

**Power Cable Potting**

**WARNING**

////////////////////////////////////  
// Do not attempt to operate this pump unless the power ca- //  
// ble terminals (except for the ground terminal) are prop- //  
// erly potted or sealed with heat-shrink tubing and bonded //  
// to the terminal plate. Moisture entering the terminal //  
// housing could cause a short circuit, resulting in death //  
// or injury to personnel. //  
// //  
////////////////////////////////////

If the power cable terminals were removed from the leads, the connections **must** be resealed with a water-tight material such as electrical potting compound or heat-shrink tube.

When shipped from the factory, the cable leads and terminals were encapsulated in heat-shrink tubing (44) and bonded to the terminal plate (47) with hot-melt adhesive to provide a water-tight seal. These materials are included in an optional repair kit listed in the parts list; however, since a glue gun with the required temperature range is not generally available in the field, it is recommended that a repotting kit available from Gorman-Rupp (see optional equipment in parts list) or a commercially available kit (Products Research Corp., part no. PR-1201-Q Class 1 potting compound, or equivalent) be used to reseat the connections. See Figure 6, and the following instructions.



## NOTE

Potting compound, hot-melt adhesive and heat-shrink tubing have the same electrical properties when correctly applied. Heat-shrink tubing is used at the factory to ease production. The advantage of using potting compound for field repairs is greater availability, and elimination of special tools.

If heat-shrink tubing is used for field repairs, use **only** materials and heating equipment approved by Gorman-Rupp.

Clean and assemble all terminal components as indicated in the potting instructions.

If removed for replacement, crimp a new terminal on each power cable lead and slide a length of shrink tube (Gorman-Rupp part number 31412-053) over each terminal. The tubing should cover the crimped part of the terminals and extend up the leads far enough to ensure a good seal. Carefully heat each tube with a torch, or commercial hot air gun capable of producing 750° F (399° C), and shrink it around the cable leads and terminals.

After the tubing has shrunk and set, secure the terminals to the terminal posts (50) with the upper nuts (45). Use a hot-melt adhesive tool (Terlan TM-80, set at 450° F (232° C)) to apply adhesive (Gorman-Rupp part number 18661-044) over the terminal posts and around the base of the heat-shrink tubes to completely insulate the electrical connections.

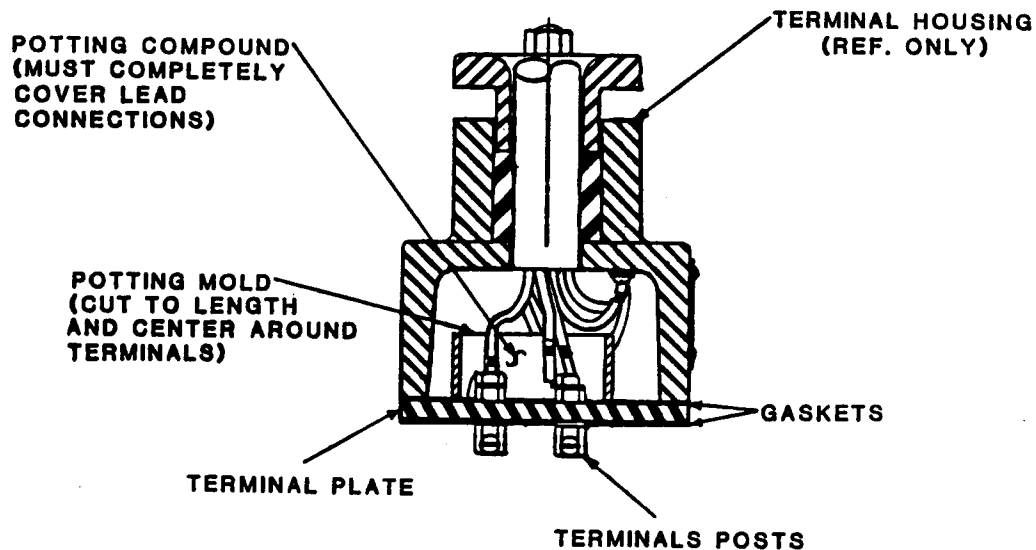

Figure 6. Potting Power Cable Leads In Terminal Housing

MAINTENANCE AND REPAIR

If the power cable is to be potted, a repotting kit is available from Gorman-Rupp (see parts list) as an option with this pump. Use this kit, or Products Research Corp. PR-1201-Q Class 1 potting compound, or equivalent.

WARNING

Do not attempt to operate this pump unless the power cable terminals (except for the ground terminal) are properly potted or sealed with heat-shrink tubing and bonded to the terminal plate. Moisture entering the terminal housing could cause a short circuit, resulting in death or injury to personnel.

Remove all the old adhesive or potting compound from the terminal posts, nuts (45) and terminal plate (47). Inspect the terminal posts for damage, and replace as required. Use a medium-grit sandpaper to prepare the surface of the terminal plate in the area of the potting mold.

NOTE

Clean the cable leads and terminal plate in areas to be potted with cleaning solvent before potting. Potting compound will not adhere properly to oil or grease coated surfaces.

If the terminals were removed from the leads, crimp a new terminal onto each lead.

Assemble the terminal posts (50), dyna seal washers (49) and lower nuts (45) to the terminal plate (47).

Trim the potting mold so it is just long enough to cover the terminal post studs (see Figure 6). Slide the potting mold up over the three standard leads of the power cable (32).

Secure the three power leads to the terminal posts (50) with the upper nuts (45). Slide the potting mold down over the terminal posts and onto the terminal plate. Hang the cable vertically with the terminal plate horizontal. The cable leads and terminal posts should be centered in the potting mold. Use quick-setting cement, such as '3-M Weather Seal' to secure the potting mold to the terminal plate.

WARNING

Most potting base compounds contain toluene; use adequate ventilation and avoid prolonged breathing of vapors. Most potting accelerators contain lead; avoid ingestion or prolonged contact with the skin. Read and follow all warnings and recommendations accompanying the potting kit.

---

---

See the instructions with the potting kit regarding application life, and setting and curing time. Mix the base compound and accelerator and fill the mold completely. Tamp the potting material to eliminate air bubbles and ensure that the material has completely covered the area around the terminal posts.

When potting has been completed, leave the terminal plate assembly undisturbed until the potting material has cured. Complete curing usually takes about 24 hours. Curing time can be shortened by using a heat lamp, but be careful not to melt the potting or potting mold, or burn the cable. When potting material is no longer "tacky" to the touch, it has cured.

After the potting material has cured, untape the ground leads and slide the terminal housing down the cable. If removed, crimp the two green ground leads to the ground terminal ( ) and crimp the yellow ground check lead to the ground check terminal ( ). Secure the ground terminals with the machine screw and lockwasher (38 and 39). Make sure the leads make good contact with the housing.

Pull gently on the power cable to remove any excess length from within the terminal housing. The terminal plate should fit loosely in the terminal housing.

Lubricate the upper bore of the terminal housing, and slide the gland bushing (37) into place. Slide the terminal gland (35) into place and install the nuts (34). Do not fully tighten the nuts at this time.

Attach the motor leads to the terminal posts (50) using the nylock machine screws (51). If required, rotate the terminal housing and twist the motor leads to remove excess slack.

Coat the threads of studs (29) with 'Never-Seez' or equivalent compound. Secure the terminal housing to the motor housing by torquing the nuts (30) to 11 ft. lbs. (132 inch lbs.).

Tighten the nuts (34) drawing the terminal gland (35) down into terminal bore. **Do not** over-tighten the nuts and damage the terminal gland or hardware.

See LUBRICATION and FINAL ASSEMBLY.

## LUBRICATION

Check the oil level in the seal cavity and motor housing before initial startup, after the first two weeks of operation, and every month thereafter. If the oil levels are abnormally low, or the color milky or dark, refer to **Draining Oil From Seal And Motor** in this section for instructions and troubleshooting tips.

### NOTE

To accurately check the oil level the pump must be cool.

The grade of lubricant used is critical to the operation of this pump. Use premium quality submersible pump oil of the grade specified in Table 1. Oil must be stored in a clean, tightly closed container in a reasonably dry environment.

Table 1. Typical Pump Oil Properties

Type .....	Premium high viscosity index, anti-wear hydraulic oil
Dielectric .....	26,000(volts-min)
Pour point .....	-20°F to -60°F
Viscosity @ 100°F .....	110 to 155
Viscosity @ 210°F .....	40 to 50
Recommended supplier:	
Gulf Oil Company .....	Gulf Harmony HVI AW 26
Acceptable alternate suppliers:	
Gulf Oil Company .....	Gulf Harmony 32 AW
SOHIO * .....	Energol - HLP 32
Shell Oil Company .....	Tellus 32, Tellus T-23 or T-32
Sun Oil Co. ....	Sunvis 816 or 916
Texaco .....	Rando HD 32 or HD AZ 32
A.R.CO. ....	Duro 32
Exxon .....	Nuto H 32

\* Also Boron & B.P. (British Petroleum) Oil Companies

### Seal Cavity

Lay the pump on its side, remove the seal cavity drain/fill plug (64B) in the intermediate, and add approximately 1-1/4 pints of the recommended grade of submersible pump oil. Apply 'Loctite Pipe Sealant With Teflon No. 592', or equivalent sealant, to the threads of the drain/fill plug, and reinstall and tighten the plug.

### Motor Housing Cavity

With the pump in an upright position, remove the socket head pipe plug (25) on top of the pump and add approximately 3 quarts of the recommended grade of submersible pump oil. Apply 'Loctite Pipe Sealant With Teflon No. 592', or equivalent sealant, to the threads of the pipe plug and reinstall the plug.

### FINAL ASSEMBLY

If the discharge flange (21) was separated from the upper motor housing, replace the gasket (18), and secure the flange with the nuts (20).

Connect the discharge hose, and position the pump in the wet well. If rigid discharge piping is used, connect the piping after the pump has been positioned. Open any valves in the discharge line.

---

---

### Motor Housing Cavity

With the pump in an upright position, remove the socket head pipe plug (25) on top of the pump and add approximately 3 quarts of the recommended grade of submersible pump oil. Apply 'Loctite Pipe Sealant With Teflon No. 592', or equivalent sealant, to the threads of the pipe plug and reinstall the plug.

### FINAL ASSEMBLY

If the discharge flange (21) was separated from the upper motor housing, replace the gasket (18), and secure the flange with the nuts (20).

Connect the discharge hose, and position the pump in the wet well. If rigid discharge piping is used, connect the piping after the pump has been positioned. Open any valves in the discharge line.

**For U.S. and International Warranty Information,  
Please Visit [www.grpumps.com/warranty](http://www.grpumps.com/warranty)  
or call:  
U.S.: 419-755-1280  
International: +1-419-755-1352**

**For Canadian Warranty Information,  
Please Visit [www.grcanada.com/warranty](http://www.grcanada.com/warranty)  
or call:  
519-631-2870**